



HIGH SPEED STEEL

METRIC 1/2" SHANK SILVER & DEMING DRILLS

ICS WIS

GENERAL PURPOSE

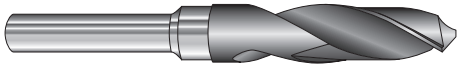
118° POINT

ITEM NO.	ILLUSTRATION	CUTTING APPLICATION	STEEL SPECS	TECHNICAL DATA
SNDM	 BLACK & SILVER FINISH	For portable or machine drilling in ferrous or non-ferrous metals. Ground oxide finish flutes retain lubricants and ease chip welding when drilling cast iron, steel, etc.	M2	118° Point Std. Spiral
SNDM3F	 BLACK & SILVER FINISH	Flats are ground on three sides of drill shank for positive holding in 3-Jaw Chucks.	M2	118° Point Std. Spiral

Metric Sizes (Reduced Shank) 13.00mm to 38.00mm Dia.

SIZE mm	DEC. EQUIV.	HIGH SPEED STEEL	
		ROUND SHANK 118° PT	3 FLAT SHANK 118° PT
		SNDM	SNDM3F
13.00	.5118	22.50	27.58
13.50	.5315	22.50	27.58
14.00	.5512	23.80	28.86
14.50	.5709	25.30	30.42
15.00	.5906	25.30	30.42
15.50	.6102	26.34	31.44
16.00	.6299	26.34	31.44
16.50	.6496	28.92	34.00
17.00	.6693	28.92	34.00
17.50	.6890	30.18	35.24
18.00	.7087	30.18	35.24
18.50	.7283	31.48	36.58
19.00	.7480	31.48	36.58
19.50	.7677	34.16	39.24
20.00	.7874	34.16	39.24
20.50	.8071	35.40	40.46
21.00	.8268	35.40	40.46

SIZE mm	DEC. EQUIV.	HIGH SPEED STEEL	
		ROUND SHANK 118° PT	3 FLAT SHANK 118° PT
		SNDM	SNDM3F
21.50	.8465	36.64	41.76
22.00	.8661	36.64	41.76
22.50	.8858	38.02	43.10
23.00	.9055	38.02	43.10
23.50	.9252	42.88	47.94
24.00	.9449	42.88	47.94
24.50	.9646	46.94	52.02
25.00	.9843	46.94	52.02
25.50	1.0039	54.80	59.90
26.00	1.0236	54.80	59.90
26.50	1.0433	57.50	62.56
27.00	1.0630	57.50	62.56
27.50	1.0837	62.60	67.66
28.00	1.1024	62.60	67.66
28.50	1.1220	66.16	71.24
29.00	1.1417	66.16	71.24
29.50	1.1614	68.02	73.08

SIZE mm	DEC. EQUIV.	HIGH SPEED STEEL	
		ROUND SHANK 118° PT	3 FLAT SHANK 118° PT
		SNDM	SNDM3F
30.00	1.1811	68.02	73.08
30.50	1.2008	68.98	74.06
31.00	1.2205	68.98	74.06
31.50	1.2402	73.02	78.08
32.00	1.2598	73.02	78.08
32.50	1.2795	81.86	86.94
33.00	1.2992	81.86	86.94
33.50	1.3189	83.96	89.04
34.00	1.3386	83.96	89.04
34.50	1.3583	86.48	91.56
35.00	1.3780	86.48	91.56
35.50	1.3976	95.76	100.84
36.00	1.4173	95.76	100.84
36.50	1.4370	99.22	104.32
37.00	1.4567	99.22	104.32
37.50	1.4764	118.60	112.36
38.00	1.4961	107.28	112.36

METRIC 1/2" SHANK SILVER & DEMING DRILL SETS

WOOD STAND

DESCRIPTION	TYPE OF DRILL	ITEM NO.	PRICE
<p>13 PC DRILL SET 13.0,13.5, 14.0, 15.0, 16.0, 17.0, 18.0, 19.0, 20.0, 21.0, 22.0, 24.0, 25.0</p> 	<p>Metric S & D Drills 118° Pt Heavy Duty Metric S & D Drills 135° S/Pt</p>	<p>DSW-SNDM-13 DSW-SNDMH-13</p>	<p>CALL FOR PRICE</p>

NOTE: Metric 3/8" Shank (Silver & Deming) Drills are available upon request.