

167C

TOOL STEEL ADJUSTABLE HOLE CUTTER

ICS

WIS

GENERAL PURPOSE

3/8"
SHANK

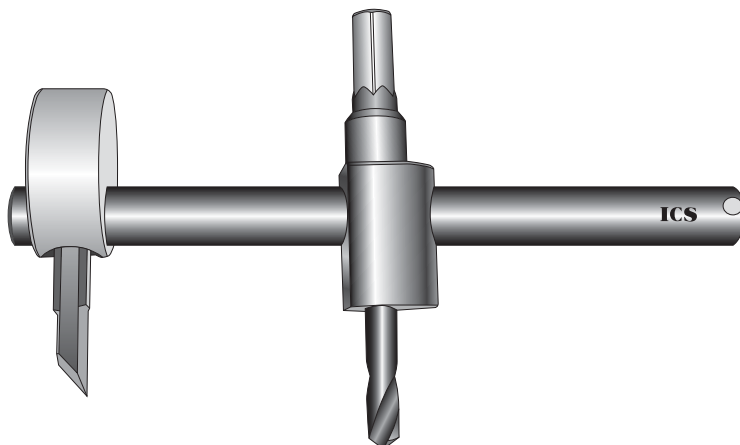

REPLACEABLE
CUTTING BLADE

The Adjustable Hole Cutter is designed for cutting 1" to 6" holes and discs in sheet metal, copper, brass, aluminum, plastic, wood and composition materials. Maximum 3/4" cutting depth. Reverse double-ended cutting blade to change from circle to wheel cutting. Used by woodworkers, hobbyists, model builders, clockmakers etc... Supplied with hex wrench, cutting bit and pilot hole drill. Use in any drill press or drill stand. Do not use in hand held power tools. Maximum safe speed 500 RPM.

ITEM NO.	FOR CUTTING	CUTTING DEPTH	SHANK	PRICE
AHC600	1" to 6" Holes	3/4	3/8	\$12.60