

HIGH SPEED STEEL

**THREE FLUTE (QUICK CHANGE) COUNTERSINKS**

ICS WIS

GENERAL PURPOSE

RIGHT HAND CUT

QUICK CHANGE  
1/4" HEX SHANK

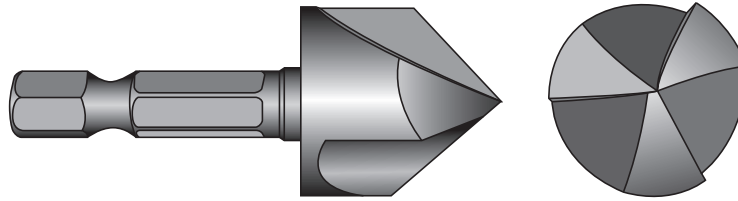

82°  
POINT ANGLE

High Speed Steel Three Flute Quick Change Countersinks fit into a 1/4" hex power driver or any 3-jaw style power drill chuck. Used to countersink most ferrous and non-ferrous metals, plastic, wood, etc...

SIZE	OVERALL LENGTH	ITEM NO.	CENTERLINE ANGLE/ INCLUDED ANGLE	PRICE
1/4	2"	CSKQC382-016	41° / 82°	5.26
3/8	2"	CSKQC382-024	41° / 82°	5.78
1/2	2"	CSKQC382-032	41° / 82°	6.30
5/8	2"	CSKQC382-040	41° / 82°	10.50
3/4	2"	CSKQC382-048	41° / 82°	12.60

TOOL STEEL / HIGH SPEED STEEL

**REPAIRMAN'S TAPER REAMER**

ICS WIS

GENERAL PURPOSE / HEAVY DUTY

60° POINT

T-HANDLE  
SHANK

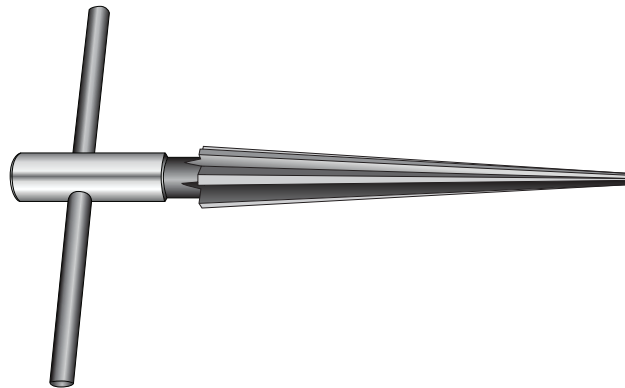

STRAIGHT  
FLUTE

Tool Steel Repairman's Taper Reamers are used to enlarge and countersink holes in soft metals, plastics, and similar materials. High Speed Steel Repairman's Taper Reamers are designed for removing burrs from small holes, tubing, and enlarging holes in sheet metal. They are used by plumbers, mechanics, electricians, and machinists. Not for use in machine power tools.

POINT DIA.	LARGE DIA.	LENGTH OF CUT	OVERALL LENGTH	SHANK DIA.	FLUTE END STYLE	ITEM NO.	PRICE
<b>TOOL STEEL</b>							
1/8	1/2	3-1/2	5-5/8	1/2	60° POINT	RTR032	11.00
3/16	5/8	4-1/4	6	12MM (.4724)	60° POINT	RTR040	12.88
3/16	5/8	4-1/4	6	9/16 HEX	60° POINT	RTR040HX	15.00
<b>HIGH SPEED STEEL</b>							
1/8	1/2	3-5/8	5-9/16	1/2	60° POINT	RTRHD032	15.50
1/8	5/8	3-5/8	5-9/16	1/2	60° POINT	RTRHD040	18.20
3/8	1	4-1/2	6	1/2	60° POINT	RTRHD100	39.96