

SPECIAL 3 STEP DRILL QUOTATION FORM

We maintain a special facility that is equipped with machines specifically designed for drill modification. We are equipped with specialized machinery to manufacture non-standard drills to print. By maintaining a large inventory of high speed and cobalt steels, we are able to reduce overall delivery time.

REQUESTING A QUOTE FOR SPECIAL STEP DRILLS IS EASY

REQUEST OPTIONS

- Print this form, fill it out and fax to 920-837-2530.
- Download this form, fill it out electronically, save and email as an attachment to sales@iccuttingtools.com

When ordering Special Step Drills, please specify the following:

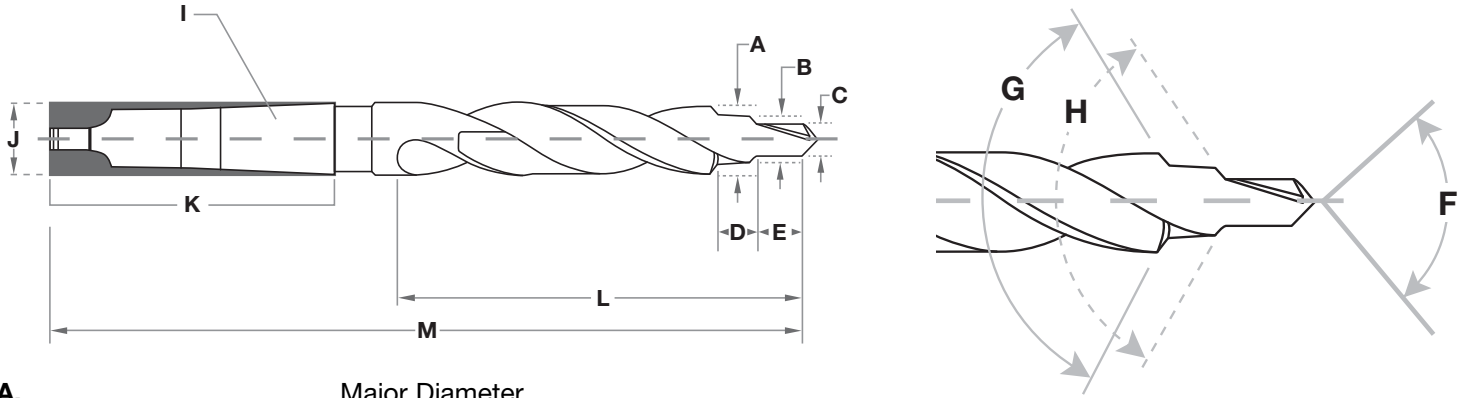

- A. _____ Major Diameter
- B. _____ Middle Diameter
- C. _____ Minor Diameter, aka Pilot Diameter (+000 -.002), unless otherwise specified
- D. _____ Middle Step Length (+/-.015), unless otherwise specified
- E. _____ Pilot Step Length (+/-.015), unless otherwise specified
- F. _____ Point Angle
- G. _____ Included Chamfer Angle
NOTE: This is the angle between the cutting edges and is not referenced as an angle with the center line
- H. _____ Included Angle for Middle Diameter
- I. _____ If taper shank, advise Morse Taper Number
- J. _____ Shank Diameter (if different than Major Diameter A)
- K. _____ Length of shank if reduced
- L. _____ Flute Length
- M. _____ Overall Length

QUANTITY REQUIRED

FINISH: Bright Oxide Coated Other _____

HELIX: Standard Fast Slow Other _____

TOOL MATERIAL: High Speed Cobalt Other _____

Right Hand Left Hand

CONTACT INFORMATION

Contact Name: _____ Company Name: _____

Phone: _____ Fax: _____

Email: _____