

ICS Cutting Tools, Inc.

REVISED JAN 2024

CUTTING TOOL SETS



ICS CUTTING TOOLS, INC

511 Main Street • Casco, WI 54205-0125 USA

(920) 837-2526 • Fax (920) 837-2530

www.icscuttingtools.com • info@icscuttingtools.com

INDEX

BORING

Boring Bar - Carbide Tipped.....	39
Mini Toolholder & Boring Bar	39

COUNTERBORING

Capscrew Counterbores.....	18
Capscrew Counterbores - metric.....	18
Interchangeable Pilot Counterbores.....	18

COUNTERSINKING

Combined Drill & Countersinks.....	19
Countersinks.....	19
Indexable	20

FILING

Burs	
Solid Carbide.....	44-45
Files	
American Pattern.....	42
External Thread Restoring	43
Needle.....	42
Precision	43
Rasps	
Riffler	43

MASONRY CUTTING

Masonry Drills	
Fast Spiral.....	15
Wide Spiral.....	15
Masonry Hammer Drills	
Ramset Shank.....	15
SDS Shank	15

METAL CUTTING

Cutters	
Annular	14
Spot Weld.....	14
Drills	
Aircraft Drills.....	13
Combined Drill & Countersinks.....	13
Ground Drill Blanks	2
Long Boy Drills.....	12

Jobber Length Drills

7 PC (1/8 to 1/2 by 16ths).....	6
11 PC (1/16 to 3/8 by 32nds).....	7
11 PC (1.0 to 6.0 by 0.5mm).....	9
13 PC (1/16 to 1/4 by 64ths)	3
15 PC (1/16 to 1/2 by 32nds).....	3
19 PC (1.0 to 10.0 by 0.5mm)	9
20 PC (#61 to #80)	7
21 PC (1/16 to 3/8 by 64ths)	4
21 PC (1/16-1/4 by 64ths • 9/32-1/2 by 32nds) ...	4
25 PC (1.0 to 13.0 by 0.5mm)	9
29 PC (1/16 to 1/2 by 64ths)	5
26 PC (A to Z)	8
60 PC (#1 to #60).....	7
115 PC (Fractional, Wire Gauge, & Letter sizes)	8
Double Margin	2
Fast Spiral	1
Slow Spiral	1
Quick Change Hex Shank Drills.....	1
Screw Machine Length Drills	
Cobalt	1
High Speed Steel	1
Silver & Deming Drills	
3/8" Shank	
8 PC (9/16 to 1 by 16ths).....	11
1/2" Shank	
5 PC (1 to 1-1/2 by 8ths)	10
8 PC (9/16 to 1 by 16ths).....	10
8 PC (13, 14, 16, 18, 20, 22, 24, & 25mm)	11
8 PC (9/16 to 1 by 16ths) merchandiser.....	11
13 PC (17/32 - 3/4 by 32nds).....	10
(13/16 - 1 by 16ths & 31/32)	
32 PC (33/64 to 1 by 64ths)	10
Step Drills	13
Taper Length Drills.....	12

REAMING

Adjustable Hand Reamers.....	22
Adjustable Hand Reamers (Long Pilot).....	22
Automotive Reamers.....	21
Chucking Reamers.....	21
Jobber Reamers.....	21
Silver & Deming Reamers	20
Taper Pin Reamers.....	21
Tower Bolt Reamers.....	22

SAWING

Hole Cutter Kit	
Carbide Tipped.....	41
Hole Saw Kits	
Carbide Grit Edged.....	41
Carbide Tipped.....	41
Built-in Arbor	40
Separate Arbor.....	40

THREADING

Bolt & Nut Extractors	24
Dies	
Hex Rethreading Dies	26
Hex Rethreading Pipe Dies	27
Hex Threading Dies.....	28
Ratcheting	
Pipe Threader	37
Tap & Die	38
Screw Extractors	
Broken Tap Extractors.....	24
Screw Extractors	23
Screw Extractors (Multi-Spline).....	23
Screw Extractors & Drills.....	23
Taps	
Model Airplane Taps	36
Taper Pipe Taps.....	25
Taper Pipe Taps - British Standard	25
Taps (dispenser only)	33
Taps & Drills	
18 pc.....	33
335 pc (dispenser only).....	33
Taps & Hex Dies	
40pc.....	29
58pc.....	30
65pc.....	30
117pc.....	31
Pipe Taps & Hex Dies	27
Taps & Round Dies	
21pc.....	34
30pc (miniature)	36
45pc.....	32
Thread Box & Tap.....	38
Thread Restoring Files & Automotive Taps	
54pc.....	35
18pc.....	35
13pc (metric).....	35

UNIVERSAL CUTTING

Carbide Tipped Universal Drills	15
---------------------------------------	----

WOOD CUTTING

Brad Point Drills	17
Forstner Bits	16
Multi-Angle Drills	16
Multi-Spur Pipe Bits.....	17
Perfect Point Drills	17
Perfect Point Silver & Deming Drills	17
Taper Point Drills.....	17
Wood Spade Bits.....	16

HIGH SPEED STEEL SCREW MACHINE LENGTH [STUB] DRILL SETS

METAL INDEX

ILLUSTRATION	CONTENTS	TYPE OF DRILL	ITEM NO.	PRICE
 <p>(13 PC PICTURED)</p>	13 PC SETS Sizes 1/16 to 1/4 by 64ths	Bright Finish Stub Drills 135° S/Pt Black Finish Stub Drills 135° S/Pt Titanium Nitride Coated Stub Drills 135° S/Pt	DS-SMP-13	22.34
	15 PC SETS Sizes 1/16 to 1/2 by 32nds	Black Finish Stub Drills 135° S/Pt	DS-SMR-13	22.34
	29 PC SETS Sizes 1/16 to 1/2 by 64ths	Bright Finish Stub Drills 135° S/Pt Black Finish Stub Drills 135° S/Pt Titanium Nitride Coated Stub Drills 135° S/Pt Gold Finish Stub Drills 135° S/Pt Cobalt Stub Drills 135° S/Pt	DS-SMT-13	47.04
	60 PC SETS Wire Gauge Sizes 1 to 60	Bright Finish Stub Drills 135° S/Pt Black Finish Stub Drills 135° S/Pt	DS-SMR-15	74.56
	25 PC SETS Metric Sizes 1.00mm to 13.00mm by 0.50mm	Black Finish Stub Drills 135° S/Pt	DS-SMP-29 DS-SMR-29 DS-SMT-29 DS-SMGF-29 DS-SMC-29	108.20 110.54 268.14 128.72 239.90
			DS-SMP-60 DS-SMR-60	88.20 88.20
			DS-SMM-25	180.40

HIGH SPEED STEEL COBALT SCREW MACHINE LENGTH DRILL SETS

METAL INDEX

CONTENTS	TYPE OF DRILL	ITEM NO.	PRICE
29 PC SETS Sizes 1/16 to 1/2 by 64ths	Cobalt Stub Drills - 135° Split Point	DS-SMC-29	239.90

HIGH SPEED STEEL FAST/SLOW SPIRAL JOBBER LENGTH DRILL SETS

METAL INDEX

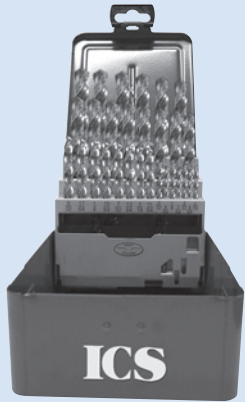
ILLUSTRATION	CONTENTS	TYPE OF DRILL	ITEM NO.	PRICE
	29 PC SETS 1/16 to 1/2 by 64ths	Fast Spiral Jobber Drill - 118° Pt Slow Spiral Jobber Drill - 118° Pt	DS-JDF-29 DS-JDS-29	182.20 210.66

1/4" QUICK CHANGE HEX SHANK DRILL SETS

PLASTIC INDEX

CONTENTS	TYPE OF DRILL	ITEM NO.	PRICE
10 PC SETS 1/16 to 5/32 by 64ths 3/16 to 1/4 by 32nds (Wt. .40 lbs.)	1/4" Hex Shank Drills - 118° Standard Point 1/4" Hex Shank Drills - 135° Split Point	DS-QHSD-10 DS-QHSDH-10	39.32 43.84

HIGH SPEED STEEL DOUBLE MARGIN JOBBER LENGTH DRILL SETS

METAL INDEX

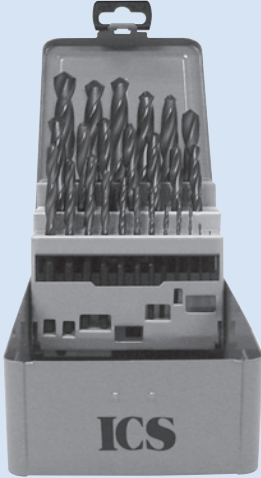
DESCRIPTION	CONTENTS	ITEM NO.	PRICE
 <p>(Wt. 1.40 lbs.)</p>	7 PC SET 1/8 to 1/2 by 16ths Bright Finish Double Margin Jobber Drill 118° S/P	DS-JDDMHA-7	65.92
 <p>(Wt. 3.30 lbs.)</p>	25 PC SET 1/8 to 1/2 by 64ths Bright Finish Double Margin Jobber Drill 118° S/P	DS-JDDMHA-25	184.12

HIGH SPEED STEEL GROUND DRILL BLANK SETS

METAL INDEX

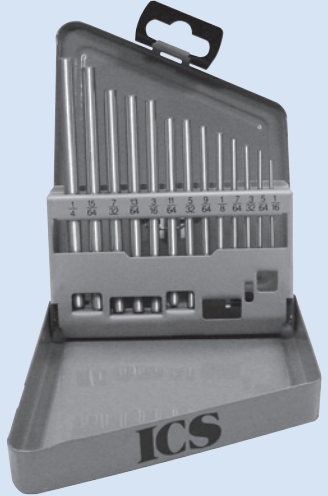
ILLUSTRATION	CONTENTS	ITEM NO.	PRICE
	13 PC SET 1/16 to 1/4 by 64ths	GDBS-13	23.00
	15 PC SET 1/16 to 1/2 by 32nds	GDBS-15	59.36
	29 PC SET 1/16 to 1/2 by 64ths	GDBS-29	102.58
	60 PC SET Wire Gauge Sizes: #1 to #60	GDBS-60	89.08
	20 PC SET Wire Gauge Sizes: #61 to #80	GDBS-20	29.18
	26 PC SET Letter Sizes: A to Z	GDBS-26	112.98

JOBBER LENGTH DRILL SETS

METAL INDEX

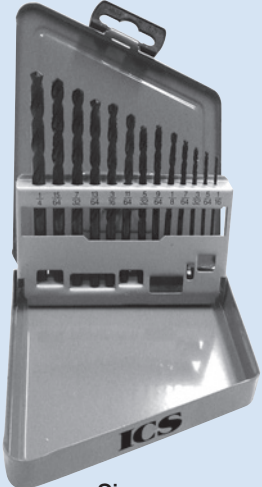
DESCRIPTION	TYPE OF DRILL	ITEM NO.	PRICE
13 PC DRILL SET  Sizes 1/16 to 1/4 by 64ths (Wt. .80 lbs.)	GENERAL PURPOSE - HIGH SPEED STEEL		
	Black Finish Roll Fluted Jobber Drill 118° Pt	DS-JDR-13	17.64
	Bright Finish Jobber Drill 118° Pt	DS-JDP-13	18.24
	Black Finish Jobber Drill 118° Pt	DS-JDG-13	18.24
	GENERAL PURPOSE - SPECIAL COATING - HIGH SPEED STEEL		
	Titanium Nitride Coated Jobber Drill 118° Pt	DS-JDT-13	48.22
	Zirconium Nitride Coated Jobber Drill 118° Pt	DS-JDZ-13	63.56
	HEAVY DUTY - HIGH SPEED STEEL		
	Bright Finish Jobber Drill 118° S/Pt	DS-JDHA-13	23.30
	Black Finish Jobber Drill 135° S/Pt	DS-JDHB-13	23.30
	Bright Finish Jobber Drill 135° S/Pt	DS-JDHP-13	23.30
	Gold Finish Jobber Drill 135° S/Pt	DS-JDHGF-13	23.30
	Black & Gold Dual Finish Jobber Drill 135° S/Pt	DS-JDHDF-13	27.06
	HEAVY DUTY - SPECIAL COATING - HIGH SPEED STEEL		
	Titanium Nitride Coated Jobber Drill 135° S/Pt	DS-JDHT-13	51.04
	HEAVY DUTY - LEFT HAND - HIGH SPEED STEEL		
	Gold Finish Left Hand Jobber Drill 135° S/Pt	DS-JDL-13	51.04
	HEAVY DUTY - COBALT		
	Gold Finish Cobalt Jobber Drill 135° S/Pt	DS-JDC-13	37.64

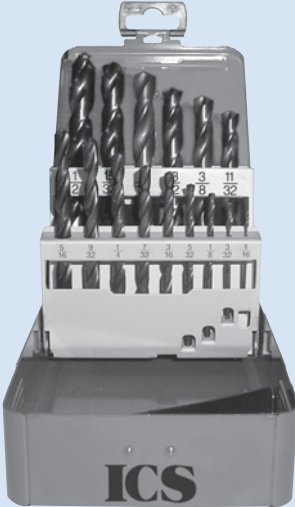
DESCRIPTION	TYPE OF DRILL	ITEM NO.	PRICE
15 PC DRILL SET  Sizes 1/16 to 1/2 by 32nds (Wt. 2.10 lbs.)	GENERAL PURPOSE - HIGH SPEED STEEL		
	Black Finish Roll Fluted Jobber Drill 118° Pt	DS-JDR-15	51.74
	Bright Finish Jobber Drill 118° Pt	DS-JDP-15	52.92
	Black Finish Jobber Drill 118° Pt	DS-JDG-15	52.92
	GENERAL PURPOSE - SPECIAL COATING - HIGH SPEED STEEL		
	Titanium Nitride Coated Jobber Drill 118° Pt	DS-JDT-15	131.72
	Zirconium Nitride Coated Jobber Drill 118° Pt	DS-JDZ-15	211.54
	GENERAL PURPOSE - REDUCED SHANK - HIGH SPEED STEEL		
	Black Finish 1/4" SHANK Roll Fluted Jobber Drill 118° Pt	DS-JDRQS-15	59.98
	Bright Finish 1/4" SHANK Jobber Drill 118° Pt	DS-JDPQS-15	63.82
	Black Finish 1/4" SHANK Jobber Drill 118° Pt	DS-JDGQS-15	63.82
	Black Finish 3/8" SHANK Roll Fluted Jobber Drill 118° Pt	DS-JDRTS-15	57.62
	Bright Finish 3/8" SHANK Jobber Drill 118° Pt	DS-JDPTS-15	61.30
	Black Finish 3/8" SHANK Jobber Drill 118° Pt	DS-JDGTS-15	61.30
	HEAVY DUTY - HIGH SPEED STEEL		
	Black Finish Jobber Drill 118° S/Pt	DS-JDHA-15	63.50
	Black Finish Jobber Drill 135° S/Pt	DS-JDHB-15	63.50
	Bright Finish Jobber Drill 135° S/Pt	DS-JDHP-15	63.50
	Gold Finish Jobber Drill 135° S/Pt	DS-JDHGF-15	66.86
	Black & Gold Dual Finish Jobber Drill 135° S/Pt	DS-JDHDF-15	72.10
	HEAVY DUTY - SPECIAL COATING - HIGH SPEED STEEL		
	Titanium Nitride Coated Jobber Drill 135° S/Pt	DS-JDHT-15	152.00
	HEAVY DUTY - LEFT HAND - HIGH SPEED STEEL		
	Gold Finish Left Hand Jobber Drill 135° S/Pt	DS-JDL-15	121.98
	HEAVY DUTY - COBALT - STRAIGHT SHANK & REDUCED		
	Gold Finish Cobalt Jobber Drill 135° S/Pt	DS-JDC-15	105.84
	Gold Finish 3/8" SHANK Cobalt Jobber Drill 135° S/Pt	DS-JDCTS-15	132.30
	HEAVY DUTY - REDUCED SHANK - HIGH SPEED STEEL		
Black Finish 1/4" SHANK Jobber Drill 135° S/Pt	DS-JDHBQS-15	88.20	
Bright Finish 1/4" SHANK Jobber Drill 135° S/Pt	DS-JDHPQS-15	88.20	
Gold Finish 1/4" SHANK Jobber Drill 135° S/Pt	DS-JDHGFQS-15	92.86	
Black Finish 3/8" SHANK Jobber Drill 135° S/Pt	DS-JDHBTS-15	76.44	
Bright Finish 3/8" SHANK Jobber Drill 135° S/Pt	DS-JDHPTS-15	76.44	
Gold Finish 3/8" SHANK Jobber Drill 135° S/Pt	DS-JDHGFTS-15	76.44	
Black & Gold Dual Finish 3/8" SHANK Jobber Drill 135° S/Pt	DS-JDHDFTS-15	88.20	

JOBBER LENGTH DRILL SETS

METAL INDEX

DESCRIPTION	TYPE OF DRILL	ITEM NO.	PRICE
21 PC DRILL SET  Sizes 1/16 to 3/8 by 64ths (Wt. 1.70 lbs.)	GENERAL PURPOSE - HIGH SPEED STEEL		
	Black Finish Roll Fluted Jobber Drill 118° Pt	DS-JDR-21	44.70
	Bright Finish Jobber Drill 118° Pt	DS-JDP-21	47.04
	Black Finish Jobber Drill 118° Pt	DS-JDG-21	47.04
	GENERAL PURPOSE - SPECIAL COATING - HIGH SPEED STEEL		
	Titanium Nitride Coated Jobber Drill 118° Pt	DS-JDT-21	132.10
	Zirconium Nitride Coated Jobber Drill 118° Pt	DS-JDZ-21	169.90
	HEAVY DUTY - HIGH SPEED STEEL		
	Black Finish Jobber Drill 118° S/Pt	DS-JDHA-21	56.46
	Black Finish Jobber Drill 135° S/Pt	DS-JDHB-21	56.46
	Bright Finish Jobber Drill 135° S/Pt	DS-JDHP-21	56.46
	Gold Finish Jobber Drill 135° S/Pt	DS-JDHGF-21	60.06
	Black & Gold Dual Finish Jobber Drill 135° S/Pt	DS-JDHDF-21	63.50
	HEAVY DUTY - SPECIAL COATING - HIGH SPEED STEEL		
	Titanium Nitride Coated Jobber Drill 135° S/Pt	DS-JDHT-21	138.10
	HEAVY DUTY - LEFT HAND - HIGH SPEED STEEL		
Gold Finish Left Hand Jobber Drill 135° S/Pt	DS-JDL-21	132.58	
HEAVY DUTY - COBALT			
Gold Finish Cobalt Jobber Drill 135° S/Pt	DS-JDC-21	96.44	

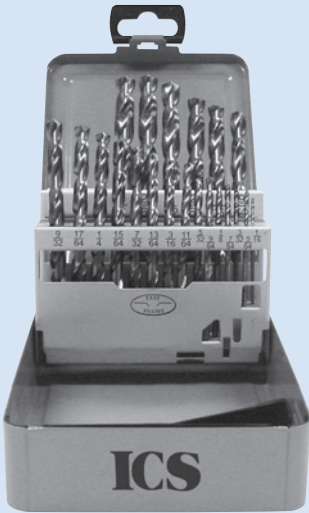
DESCRIPTION	TYPE OF DRILL	ITEM NO.	PRICE
21 PC DRILL SET  Sizes 1/16 to 1/4 by 64ths 9/32 to 1/2 by 32nds (Wt. 2.40 lbs.)	GENERAL PURPOSE - HIGH SPEED STEEL		
	Black Finish Roll Fluted Jobber Drill 118° Pt	DS-JDR-21A	64.68
	Bright Finish Jobber Drill 118° Pt	DS-JDP-21A	68.84
	Black Finish Jobber Drill 118° Pt	DS-JDG-21A	68.84
	GENERAL PURPOSE - SPECIAL COATING - HIGH SPEED STEEL		
	Titanium Nitride Coated Jobber Drill 118° Pt	DS-JDT-21A	156.26
	GENERAL PURPOSE - REDUCED SHANK - HIGH SPEED STEEL		
	Black Finish 1/4" SHANK Roll Fluted Jobber Drill 118° Pt	DS-JDRQS-21A	70.56
	Bright Finish 1/4" SHANK Jobber Drill 118° Pt	DS-JDPQS-21A	75.06
	Black Finish 1/4" SHANK Jobber Drill 118° Pt	DS-JDQGS-21A	75.06
	Black Finish 1/4" SHANK Mechanics Jobber Drill 118° Pt	DS-MLDQS-21A	87.62
	Bright Finish 1/4" SHANK Mechanics Jobber Drill 118° Pt	DS-MLDPQS-21A	87.62
	HEAVY DUTY - HIGH SPEED STEEL		
	Black Finish Jobber Drill 118° S/Pt	DS-JDHA-21A	75.86
	Black Finish Jobber Drill 135° S/Pt	DS-JDHB-21A	75.86
	Bright Finish Jobber Drill 135° S/Pt	DS-JDHP-21A	75.86
	Gold Finish Jobber Drill 135° S/Pt	DS-JDHGF-21A	80.70
	Black & Gold Dual Finish Jobber Drill 135° S/Pt	DS-JDHDF-21A	85.32
	HEAVY DUTY - SPECIAL COATING - HIGH SPEED STEEL		
	Titanium Nitride Coated Jobber Drill 135° S/Pt	DS-JDHT-21A	189.60
	HEAVY DUTY - LEFT HAND - HIGH SPEED STEEL		
Gold Finish Left Hand Jobber Drill 135° S/Pt	DS-JDL-21A	155.16	
HEAVY DUTY - COBALT			
Gold Finish Cobalt Jobber Drill 135° S/Pt	DS-JDC-21A	128.18	
HEAVY DUTY - REDUCED SHANK - HIGH SPEED STEEL			
Black Finish 1/4" SHANK Jobber Drill 135° S/Pt	DS-JDHBQS-21A	101.38	
Bright Finish 1/4" SHANK Jobber Drill 135° S/Pt	DS-JDHPQS-21A	101.38	
Gold Finish 1/4" SHANK Jobber Drill 135° S/Pt	DS-JDHGFQS-21A	106.70	
Black Finish 1/4" SHANK Mechanics Jobber Drill 135° S/Pt	DS-MLDHQS-21A	101.38	
Bright Finish 1/4" SHANK Mechanics Jobber Drill 135° S/Pt	DS-MLDHPQS-21A	101.38	

JOBBER LENGTH DRILL SETS

METAL INDEX

DESCRIPTION	TYPE OF DRILL	ITEM NO.	PRICE
29 PC DRILL SET  Sizes 1/16 to 1/2 by 64ths (Wt. 3.30 lbs.)	GENERAL PURPOSE - HIGH SPEED STEEL		
	Black Finish Roll Fluted Jobber Drill 118° Pt	DS-JDR-29	88.20
	Bright Finish Jobber Drill 118° Pt	DS-JDP-29	90.56
	Black Finish Jobber Drill 118° Pt	DS-JDG-29	90.56
	GENERAL PURPOSE - SPECIAL COATING - HIGH SPEED STEEL		
	Titanium Nitride Coated Jobber Drill 118° Pt	DS-JDT-29	276.44
	Zirconium Nitride Coated Jobber Drill 118° Pt	DS-JDZ-29	342.74
	GENERAL PURPOSE - REDUCED SHANK - HIGH SPEED STEEL		
	Black Finish 1/4" SHANK Roll Fluted Jobber Drill 118° Pt	DS-JDRQS-29	108.20
	Bright Finish 1/4" SHANK Jobber Drill 118° Pt	DS-JDPQS-129	110.54
	Black Finish 1/4" SHANK Jobber Drill 118° Pt	DS-JDQGS-29	110.54
	Black Finish 3/8" SHANK Roll Fluted Jobber Drill 118° Pt	DS-JDRTS-29	103.50
	Bright Finish 3/8" SHANK Jobber Drill 118° Pt	DS-JDPTS-29	105.84
	Black Finish 3/8" SHANK Jobber Drill 118° Pt	DS-JDGT-29	105.84
	HEAVY DUTY - HIGH SPEED STEEL		
	Black Finish Jobber Drill 118° S/Pt	DS-JDHA-29	112.90
	Black Finish Jobber Drill 135° S/Pt	DS-JDHB-29	118.12
	Bright Finish Jobber Drill 135° S/Pt	DS-JDHP-29	112.90
	Gold Finish Jobber Drill 135° S/Pt	DS-JDHGF-29	115.26
	Black & Gold Dual Finish Jobber Drill 135° S/Pt	DS-JDHDF-29	129.36
	HEAVY DUTY - SPECIAL COATING - HIGH SPEED STEEL		
	Titanium Nitride Coated Jobber Drill 135° S/Pt	DS-JDHT-29	291.66
	HEAVY DUTY - LEFT HAND/REDUCED SHANK - HIGH SPEED STEEL		
	Gold Finish Left Hand Jobber Drill 135° S/Pt	DS-JDL-29	248.18
	Gold Finish Left Hand 3/8" SHANK Jobber Drill 135° S/Pt	DS-JDLTS-29	265.10
	HEAVY DUTY - COBALT/REDUCED SHANK		
	Gold Finish Cobalt Jobber Drill 135° S/Pt	DS-JDC-29	176.40
	Gold Finish Cobalt 3/8" SHANK Jobber Drill 135° S/Pt	DS-JDCTS-29	211.68
	HEAVY DUTY - REDUCED SHANK - HIGH SPEED STEEL		
Black Finish 1/4" SHANK Jobber Drill 135° S/Pt	DS-JDHBQS-29	160.40	
Bright Finish 1/4" SHANK Jobber Drill 135° S/Pt	DS-JDHPQS-29	160.40	
Gold Finish 1/4" SHANK Jobber Drill 135° S/Pt	DS-JDHGFQS-29	155.86	
Black & Gold Dual Finish 1/4" SHANK Jobber Drill 135° S/Pt	DS-JDHDFQS-29	-	
Black Finish 3/8" SHANK Jobber Drill 135° S/Pt	DS-JDHBTS-29	136.72	
Bright Finish 3/8" SHANK Jobber Drill 135° S/Pt	DS-JDHPTS-29	136.72	
Gold Finish 3/8" SHANK Jobber Drill 135° S/Pt	DS-JDHGFTS-29	139.50	
Black & Gold Dual Finish 3/8" SHANK Jobber Drill 135° S/Pt	DS-JDHDFTS-29	152.88	
SPECIAL PURPOSE - HIGH SPEED STEEL			
Bright Finish Fast Spiral Jobber Drill 118° Pt	DS-JDF-29	182.20	
Bright Finish Slow Spiral Jobber Drill 118° Pt	DS-JDS-29	210.66	
SPECIAL VALUE PACK - HIGH SPEED STEEL			
Black Finish Roll Fluted Jobber Drill 118° Pt and 16' Power Tape (Shrink Wrapped)	DS-JDR-29VP	88.20	
GUARANTEED BEST IMPORT - HIGH SPEED STEEL			
Black Finish Roll Fluted Jobber Drill 118° Pt	DS-IJDR-29	52.92	
PERFECT POINT - HIGH SPEED STEEL			
Bright Finish Jobber Drill - Perfect Point®	DS-JD-PP-29	220.50	

JOBBER LENGTH DRILL SETS

METAL INDEX

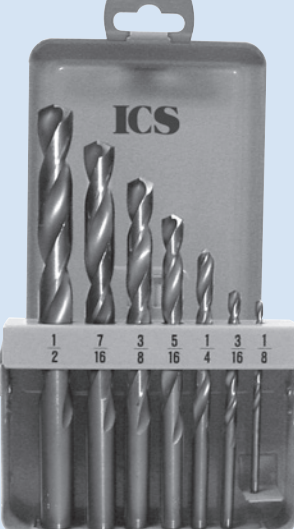
DESCRIPTION	TYPE OF DRILL	ITEM NO.	PRICE
7 PC DRILL SET  <p>Sizes 1/8 to 1/2 by 16ths (Wt. 1.40 lbs.)</p>	GENERAL PURPOSE - HIGH SPEED STEEL		
	Black Finish Roll Fluted Jobber Drill 118° Pt	DS-JDR-7	44.04
	Bright Finish Jobber Drill 118° Pt	DS-JDP-07	45.58
	Black Finish Jobber Drill 118° Pt	DS-JDG-07	45.58
	GENERAL PURPOSE - SPECIAL COATING - HIGH SPEED STEEL		
	Titanium Nitride Coated Jobber Drill 118° Pt	DS-JDT-7	91.00
	Zirconium Nitride Coated Jobber Drill 118° Pt	DS-JDZ-7	91.00
	Titanium Carbonitride Coated Jobber Drill 118° Pt	DS-JDTC-7	135.00
	Titanium Aluminum Nitride Jobber Drill 118° Pt	DS-JDTAL-7	135.00
	GENERAL PURPOSE - REDUCED SHANK - HIGH SPEED STEEL		
	Black Finish 1/4" SHANK Roll Fluted Jobber Drill 118° Pt	DS-JDRQS-7	49.74
	Bright Finish 1/4" SHANK Jobber Drill 118° Pt	DS-JDPQS-7	53.48
	Black Finish 1/4" SHANK Jobber Drill 118° Pt	DS-JDGQS-7	53.48
	Black Finish 3/8" SHANK Roll Fluted Jobber Drill 118° Pt	DS-JDRTS-7	46.94
	Bright Finish 3/8" SHANK Jobber Drill 118° Pt	DS-JDPTS-7	49.78
	Black Finish 3/8" SHANK Jobber Drill 118° Pt	DS-JDGTS-7	49.78
	HEAVY DUTY - HIGH SPEED STEEL		
	Black Finish Jobber Drill 118° S/Pt	DS-JDHA-7	51.80
	Black Finish Jobber Drill 135° S/Pt	DS-JDHB-7	51.80
	Bright Finish Jobber Drill 135° S/Pt	DS-JDHP-7	51.80
	Gold Finish Jobber Drill 135° S/Pt	DS-JDHGF-7	51.80
	Black & Gold Dual Finish Jobber Drill 135° S/Pt	DS-JDHDF-7	53.76
	HEAVY DUTY - SPECIAL COATING - HIGH SPEED STEEL		
	Titanium Nitride Coated Jobber Drill 135° S/Pt	DS-JDHT-7	97.46
	Zirconium Nitride Coated Jobber Drill 135° S/Pt	DS-JDHZ-7	115.92
	Titanium Carbonitride Coated Jobber Drill 135° S/Pt	DS-JDHTC-7	145.34
	Titanium Aluminum Nitride Coated Jobber Drill 135° S/Pt	DS-JDHTA-7	145.34
	HEAVY DUTY - LEFT HAND/REDUCED SHANK - HIGH SPEED STEEL		
	Gold Finish Left Hand Jobber Drill 135° S/Pt	DS-JDL-7	80.90
	Gold Finish Left Hand 3/8" SHANK Jobber Drill 135° S/Pt	DS-JDLTS-7	85.14
	HEAVY DUTY - COBALT/REDUCED SHANK		
	Gold Finish Cobalt Jobber Drill 135° S/Pt	DS-JDC-7	77.76
	Gold Finish Cobalt 3/8" SHANK Jobber Drill 135° S/Pt	DS-JDCTS-7	85.14
HEAVY DUTY - REDUCED SHANK - HIGH SPEED STEEL			
Black Finish 1/4" SHANK Jobber Drill 135° S/Pt	DS-JDHBQS-7	62.02	
Bright Finish 1/4" SHANK Jobber Drill 135° S/Pt	DS-JDH PQS-7	62.02	
Gold Finish 1/4" SHANK Jobber Drill 135° S/Pt	DS-JDHGFQS-7	62.02	
Black & Gold Dual Finish 1/4" SHANK Jobber Drill 135° S/Pt	DS-JDHDFQS-7	CALL	
Black Finish 3/8" SHANK Jobber Drill 135° S/Pt	DS-JDHBTS-7	56.02	
Bright Finish 3/8" SHANK Jobber Drill 135° S/Pt	DS-JDHPTS-7	56.02	
Gold Finish 3/8" SHANK Jobber Drill 135° S/Pt	DS-JDHGFTS-7	56.02	
Black & Gold Dual Finish 3/8" SHANK Jobber Drill 135° S/Pt	DS-JDHDFTS-7	58.86	
SPECIAL PURPOSE - HIGH SPEED STEEL			
Bright Finish Fast Spiral Jobber Drill 118° Pt	DS-JDF-7	62.26	
Bright Finish Slow Spiral Jobber Drill 118° Pt	DS-JDS-7	68.52	
SPECIAL PURPOSE - CARBIDE TIPPED			
Bright Finish Carbide Tipped Jobber Drill 118° Pt	DS-CTJD-7	225.96	
SPECIAL PURPOSE - SOLID CARBIDE			
Bright Finish Solid Carbide Jobber Drill 118° Pt	DS-SCJD-7	571.18	
SPECIAL POINT - HIGH SPEED STEEL			
Oxide Finish Jobber Drill - Bickford® Point	DS-JD-BP-7	73.76	
Oxide Finish Jobber Drill - Racon® Point	DS-JD-RP-7	64.68	
Oxide Finish Jobber Drill - Six Shooter® Point	DS-JD-SSP-7	64.44	
PERFECT POINT - HIGH SPEED STEEL			
Bright Finish Jobber Drill - Perfect Point®	DS-JD-PP-7	64.66	

JOBBER LENGTH DRILL SETS

METAL INDEX

DESCRIPTION	TYPE OF DRILL	ITEM NO.	PRICE
 <p>Sizes 1/16 to 3/8 by 32nds (Wt. 1.30 lbs.)</p>	GENERAL PURPOSE - HIGH SPEED STEEL		
	Black Finish Roll Fluted Jobber Drill 118° Pt	DS-JDR-11	29.40
	Bright Finish Jobber Drill 118° Pt	DS-JDP-11	29.40
	Black Finish Jobber Drill 118° Pt	DS-JDG-11	29.40
	GENERAL PURPOSE - SPECIAL COATING - HIGH SPEED STEEL		
	Titanium Nitride Coated Jobber Drill 118° Pt	DS-JDT-11	76.10
	HEAVY DUTY - HIGH SPEED STEEL		
	Bright Finish Jobber Drill 118° S/Pt	DS-JDHA-11	35.54
	Black Finish Jobber Drill 135° S/Pt	DS-JDHB-11	37.78
	Bright Finish Jobber Drill 135° S/Pt	DS-JDHP-11	37.78
	Gold Finish Jobber Drill 135° S/Pt	DS-JDHGF-11	38.96
	HEAVY DUTY - LEFT HAND - HIGH SPEED STEEL		
	Gold Finish Left Hand Jobber Drill 135° S/Pt	DS-JDL-11	63.18
HEAVY DUTY - COBALT			
Gold Finish Cobalt Jobber Drill 135° S/Pt	DS-JDC-11	56.60	

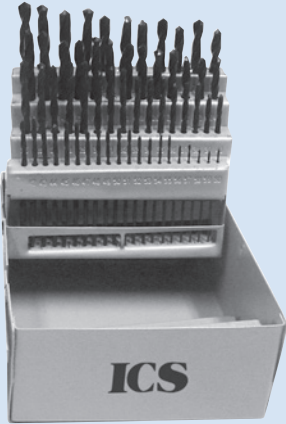
DESCRIPTION	TYPE OF DRILL	ITEM NO.	PRICE
 <p>Wire Gauge Sizes 1 to 60 (Wt. 1.10 lbs.)</p>	GENERAL PURPOSE - HIGH SPEED STEEL		
	Black Finish Roll Fluted Jobber Drill 118° Pt	DS-JDR-60	74.10
	Bright Finish Jobber Drill 118° Pt	DS-JDP-60	78.84
	Black Finish Jobber Drill 118° Pt	DS-JDG-60	78.84
	GENERAL PURPOSE - SPECIAL COATING - HIGH SPEED STEEL		
	Titanium Nitride Coated Jobber Drill 118° Pt	DS-JDT-60	192.84
	HEAVY DUTY - HIGH SPEED STEEL		
	Bright Finish Jobber Drill 118° S/Pt	DS-JDHA-60	97.60
	Black Finish Jobber Drill 135° S/Pt	DS-JDHB-60	97.60
	Bright Finish Jobber Drill 135° S/Pt	DS-JDHP-60	97.60
	Gold Finish Jobber Drill 135° S/Pt	DS-JDHGF-60	112.22
	Black & Gold Dual Finish Jobber Drill 135° S/Pt	DS-JDHDF-60	112.22
	HEAVY DUTY - COBALT		
Gold Finish Cobalt Jobber Drill 135° S/Pt	DS-JDC-60	135.24	

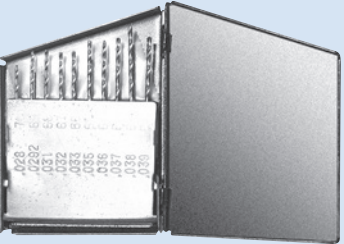
DESCRIPTION	TYPE OF DRILL	ITEM NO.	PRICE
 <p>Wire Gauge Sizes 61 to 80 (Wt. .060 lbs.)</p>	GENERAL PURPOSE - HIGH SPEED STEEL		
	Black Finish Roll Fluted Jobber Drill 118° Pt	DS-JDR-20	29.40
	Bright Finish Jobber Drill 118° Pt	DS-JDP-20	31.30
	Black Finish Jobber Drill 118° Pt	DS-JDG-20	31.30
	HEAVY DUTY - HIGH SPEED STEEL		
	Black Finish Jobber Drill 135° Pt	DS-JDHB-20	-
HEAVY DUTY - COBALT			
Gold Finish Cobalt Jobber Drill 135° Pt	DS-JDC-20	71.32	

JOBBER LENGTH DRILL SETS

METAL INDEX

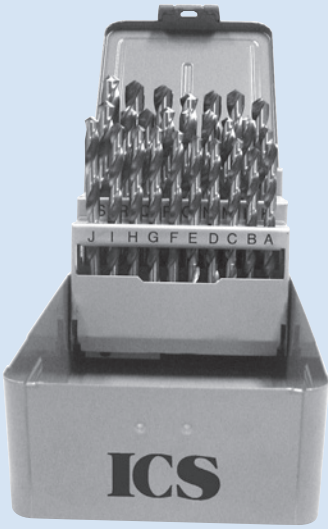
DESCRIPTION	TYPE OF DRILL	ITEM NO.	PRICE
 <p>26 PC DRILL SET</p> <p>Letter Sizes A to Z (Wt. 2.90 lbs.)</p>	GENERAL PURPOSE - HIGH SPEED STEEL		
	Black Finish Roll Fluted Jobber Drill 118° Pt	DS-JDR-26	88.20
	Bright Finish Jobber Drill 118° Pt	DS-JDP-26	99.96
	Black Finish Jobber Drill 118° Pt	DS-JDG-26	99.96
	GENERAL PURPOSE - SPECIAL COATING - HIGH SPEED STEEL		
	Titanium Nitride Coated Jobber Drill 118° Pt	DS-JDT-26	280.48
	GENERAL PURPOSE - REDUCED SHANK - HIGH SPEED STEEL		
	Black Finish 3/8" SHANK Roll Fluted Jobber Drill 118° Pt	DS-JDRTS-26	108.44
	Bright Finish 3/8" SHANK Jobber Drill 118° Pt	DS-JDPTS-26	114.62
	Black Finish 3/8" SHANK Jobber Drill 118° Pt	DS-JDGTS-26	114.62
	HEAVY DUTY - HIGH SPEED STEEL		
	Black Finish Jobber Drill 118° S/Pt	DS-JDHA-26	117.60
	Black Finish Jobber Drill 135° S/Pt	DS-JDHB-26	117.60
	Bright Finish Jobber Drill 135° S/Pt	DS-JDHP-26	117.60
	Gold Finish Jobber Drill 135° S/Pt	DS-JDHGF-26	123.48
	HEAVY DUTY - COBALT		
	Gold Finish Cobalt Jobber Drill 135° S/Pt	DS-JDC-26	188.16
	HEAVY DUTY - REDUCED SHANK - HIGH SPEED STEEL		
Black Finish 3/8" SHANK Jobber Drill 135° S/Pt	DS-JDHBTS-26	139.84	
Bright Finish 3/8" SHANK Jobber Drill 135° S/Pt	DS-JDHPTS-26	139.84	
Gold Finish 3/8" SHANK Jobber Drill 135° S/Pt	DS-JDHGFTS-26	147.20	

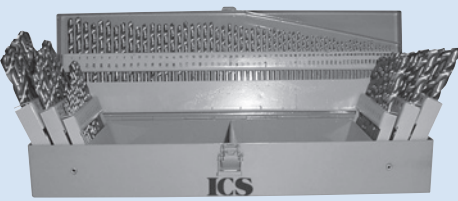
DESCRIPTION	TYPE OF DRILL	ITEM NO.	PRICE
 <p>115 PC DRILL SET</p> <p>Sizes 1/16 to 1/2 by 64ths Wire Gauge Sizes 1 to 60 Letter Sizes A to Z (Wt. 8.20 lbs.)</p>	GENERAL PURPOSE - HIGH SPEED STEEL		
	Black Finish Roll Fluted Jobber Drill 118° Pt	DS-JDR-115	264.60
	Bright Finish Jobber Drill 118° Pt	DS-JDP-115	264.60
	Black Finish Jobber Drill 118° Pt	DS-JDG-115	282.24
	GENERAL PURPOSE - SPECIAL COATING - HIGH SPEED STEEL		
	Titanium Nitride Coated Jobber Drill 118° Pt	DS-JDT-115	788.52
	GENERAL PURPOSE - REDUCED SHANK - HIGH SPEED STEEL		
	Black Finish 3/8" SHANK Roll Fluted Jobber Drill 118° Pt	DS-JDRTS-115	305.76
	Bright Finish 3/8" SHANK Jobber Drill 118° Pt	DS-JDPTS-115	305.76
	Black Finish 3/8" SHANK Jobber Drill 118° Pt	DS-JDGTS-115	305.76
	HEAVY DUTY - HIGH SPEED STEEL		
	Black Finish Jobber Drill 118° S/Pt	DS-JDHA-115	365.32
	Black Finish Jobber Drill 135° S/Pt	DS-JDHB-115	343.40
	Bright Finish Jobber Drill 135° S/Pt	DS-JDHP-115	343.40
	Gold Finish Jobber Drill 135° S/Pt	DS-JDHGF-115	365.32
	HEAVY DUTY - COBALT/REDUCED SHANK		
	Gold Finish Cobalt Jobber Drill 135° S/Pt	DS-JDC-115	635.04
	Gold Finish Cobalt 3/8" SHANK Jobber Drill 135° S/Pt	DS-JDCTS-115	694.40
HEAVY DUTY - REDUCED SHANK - HIGH SPEED STEEL			
Black Finish 3/8" SHANK Jobber Drill 135° S/Pt	DS-JDHBTS-115	391.66	
Bright Finish 3/8" SHANK Jobber Drill 135° S/Pt	DS-JDHPTS-115	391.66	
Gold Finish 3/8" SHANK Jobber Drill 135° S/Pt	DS-JDHGFTS-115	412.28	

METRIC JOBBER LENGTH DRILL SETS

METAL INDEX

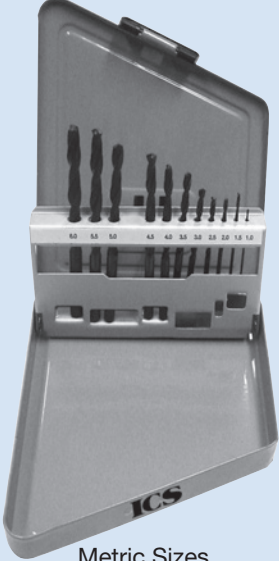
DESCRIPTION	TYPE OF DRILL	ITEM NO.	PRICE
 <p>11 PC DRILL SET</p> <p>Metric Sizes 1.0 to 6.0 by 0.5mm (Wt. .240 lbs.)</p>	GENERAL PURPOSE - HIGH SPEED STEEL		
	Black Finish Roll Fluted Jobber Drill 118° Pt	DS-JDM-11	21.28
	HEAVY DUTY - HIGH SPEED STEEL		
	Gold Finish Jobber Drill 135° S/Pt	DS-JDMHGF-11	36.98
	HEAVY DUTY - COBALT		
	Gold Finish Cobalt Jobber Drill 135° S/Pt	DS-JDCM-11	44.56

DESCRIPTION	TYPE OF DRILL	ITEM NO.	PRICE
<p>19 PC DRILL SET</p> <p>(Not Illustrated)</p> <p>Metric Sizes 1.0 to 10.0 by 0.5mm (Wt. 1.7845 lbs.)</p>	GENERAL PURPOSE - HIGH SPEED STEEL		
	Black Finish Roll Fluted Jobber Drill 118° Pt	DS-JDM-19	62.58
	HEAVY DUTY - HIGH SPEED STEEL		
	Gold Finish Jobber Drill 135° S/Pt	DS-JDMHGF-19	92.26
	HEAVY DUTY - COBALT		
	Gold Finish Cobalt Jobber Drill 135° S/Pt	DS-JDCM-19	126.02

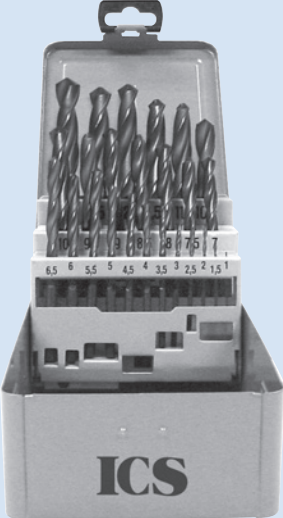

DESCRIPTION	TYPE OF DRILL	ITEM NO.	PRICE
 <p>25 PC DRILL SET</p> <p>Metric Sizes 1.0 to 13.0 by 0.5mm (Wt. 3.3125 lbs.)</p>	GENERAL PURPOSE - HIGH SPEED STEEL		
	Black Finish Roll Fluted Jobber Drill 118° Pt	DS-JDM-25	112.90
	GENERAL PURPOSE - REDUCED SHANK-HSS		
	Black Finish 3/8" Shank Roll Fluted Jobber Drill 118° Pt	DS-JDMTS-25	143.86
	HEAVY DUTY - HIGH SPEED STEEL		
	Gold Finish Jobber Drill 135° S/Pt	DS-JDHGF-25	-
	HEAVY DUTY - COBALT		
	Gold Finish Cobalt Jobber Drill 135° S/Pt	DS-JDCM-25	252.36
HEAVY DUTY - REDUCED SHANK - HSS			
	Gold Finish 3/8" SHANK Jobber Drill 135° S/Pt	DS-JDMHGFTS-25	191.42

1/2" SHANK SILVER & DEMING DRILL SETS

METAL INDEX

DESCRIPTION	TYPE OF DRILL	ITEM NO.	PRICE
8 PC DRILL DISPLAY Sizes 9/16 to 1 by 16ths 	Round SHANK S & D Drills 118° Pt	DS-SND-8	257.64
	3 Flat SHANK S & D Drills 118° Pt	DS-SND3F-8	265.70
	Cobalt S & D Drills 135° S/Pt	DS-SNDC-8	564.62
	Heavy Duty S & D Drills 135° S/Pt	DS-SNDHD-8	328.16
	Heavy Duty S & D Drills 135° Helical Pt	DS-SNDHP-8	281.64
	Titanium Nitride Coated S & D Drills 118° Pt	DS-SNDT-8	415.04

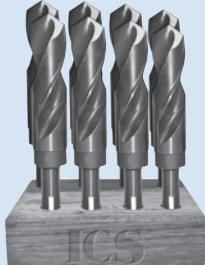
WOOD STAND

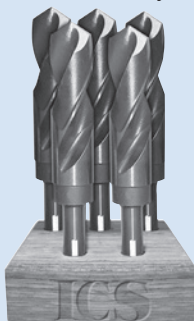
DESCRIPTION	TYPE OF DRILL	ITEM NO.	PRICE
8 PC DRILL SET Sizes 9/16 to 1 by 16ths 	Round SHANK S & D Drills 118° Pt	DSW-SND-8	246.74
	3 Flat SHANK S & D Drills 118° Pt	DSW-SND3F-8	271.76
	Cobalt S & D Drills 135° S/Pt	DSW-SNDC-8	564.62
	Heavy Duty S & D Drills 135° S/Pt	DSW-SNDHD-8	317.26
	Heavy Duty S & D Drills 135° Helical Pt	DSW-SNDHP-8	288.72
	Titanium Nitride Coated S & D Drills 118° Pt.	DSW-SNDT-8	430.66
	13 PC DRILL SET Sizes 17/32 to 3/4 by 32nds 13/16 to 1 by 16ths & 31/32 	Round SHANK S & D Drills 118° Pt	DSW-SND-13
3 Flat SHANK S & D Drills 118° Pt		DSW-SND3F-13	410.48
Cobalt S & D Drills - 135° S/Pt		DSW-SNDC-13	875.76
Heavy Duty S & D Drills 135° S/Pt		DSW-SNDHD-13	467.34
Heavy Duty S & D Drills 135° Helical Pt		DSW-SNDHP-13	435.86
Titanium Nitride Coated S & D Drills 118° Pt		DSW-SNDT-13	664.42
32 PC DRILL SET Sizes 33/64 to 1 by 64ths (NOT ILLUSTRATED)		Round SHANK S & D Drills 118° Pt	DSW-SND-32
	3 Flat SHANK S & D Drills 118° Pt	DSW-SND3F-32	1008.86
	Cobalt S & D Drills - 135° S/Pt	DSW-SNDC-32	2251.94
	Heavy Duty S & D Drills 135° S/Pt	DSW-SNDHD-32	1168.66
	Heavy Duty S & D Drills 135° Helical Pt	DSW-SNDHP-32	1087.32
	Titanium Nitride Coated S & D Drills 118° Pt	DSW-SNDT-32	1566.08
	5 PC DRILL SET Sizes 1 to 1-1/2 by 8ths 	Round SHANK S & D Drills 118° Pt	DSW-SND-5
3 Flat SHANK S & D Drills 118° Pt		DSW-SND3F-5	366.04
Titanium Nitride Coated S & D Drills 118° Pt		DSW-SNDT-5	513.64

METRIC 1/2" SHANK SILVER & DEMING DRILL SETS 11

METAL INDEX

DESCRIPTION	TYPE OF DRILL	ITEM NO.	PRICE
8 PC DRILL SET Sizes 13.0, 14.0, 16.0, 18.0, 20.0, 22.0, 24.0, 25.0	Metric S & D Drills 118° Pt	DS-SNDM-8	253.76
	Heavy Duty Metric S & D Drills 135° S/Pt	DS-SNDMH-8	317.46



HIGH SPEED STEEL - COBALT SILVER & DEMING DRILL MERCHANDISERS

DESCRIPTION	TYPE OF DRILL	ITEM NO.	PRICE
8 PC DRILL DISPLAY Sizes 9/16 to 1 by 16ths	Round Shank S & D Drills 118° Pt. - 1/2" shank	DM-SND-8	221.60
	3 Flat Shank S & D Drills 118° Pt. - 1/2" shank	DM-SND3F-8	249.82



HIGH SPEED STEEL and COBALT 3/8" SHANK SILVER & DEMING DRILL SETS

METAL INDEX

DESCRIPTION	TYPE OF DRILL	ITEM NO.	PRICE
8 PC DRILL SET Sizes 9/16 to 1 by 16ths	General Purpose 3/8 shank S & D Drills - 118° Pt.	DSW-RSD-8	247.46
	Heavy Duty 3/8 shank S & D Drills - 135° Split Pt.	DSW-RSDHB-8	311.16
	Cobalt 3/8 shank S & D Drills - 135° Split Pt.	DSW-RSDC-8	559.60



HIGH SPEED STEEL TAPER LENGTH DRILL SETS

METAL INDEX

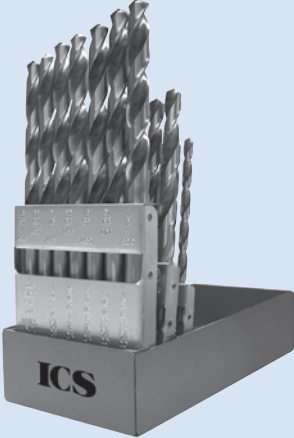
ILLUSTRATION	CONTENTS	ITEM NO.	PRICE
	16 PC SET Sizes: 33/64 to 3/4 by 64ths	DS-TLD-16	651.50
	16 PC SET Sizes: 49/64 to 1" by 64ths	DS-TLD-16A	1144.18
	26 PC SET Letter Sizes: A to Z	DS-TLD-26	393.96
	29 PC SET Sizes: 1/16 to 1/2 by 64ths	DS-TLD-29	340.46
	60 PC SET Wire Gauge Sizes: #1 to #60	DS-TLD-16	488.04

HIGH SPEED STEEL EXTRA LENGTH (LONG BOY) DRILL SETS

METAL/WOOD STANDS

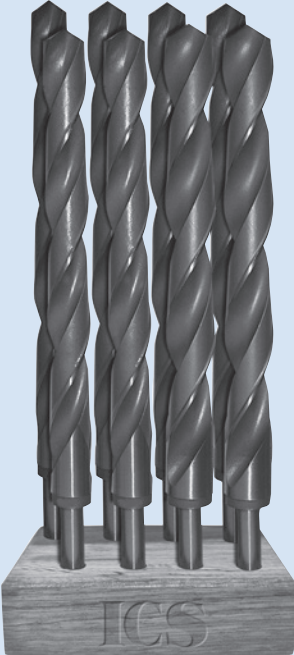
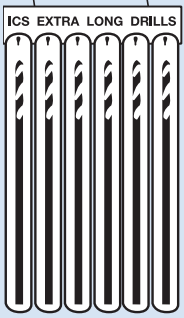

ILLUSTRATION	CONTENTS	TYPE OF DRILL	ITEM NO.	PRICE
(8 PC SET PICTURED) 	6 PC SET 3/8" Shank 3/8, 7/16, 1/2, 9/16, 5/8, 3/4 Wood Stand	3/8" Shank Heavy Duty 135° S/Pt 12" Long Boy Drills	DSW-LBH12TS-6	338.56
	8 PC SET 3/8" Shank 3/8, 13/32, 7/16, 15/32, 1/2 9/16, 5/8, 3/4 Wood Stand	3/8" Shank Heavy Duty 135° S/Pt 12" Long Boy Drills	DSW-LBH12TS-8	423.44
	8 PC SET 1/2" Shank 9/16 to 1" by 16ths Wood Stand	1/2" Shank 12" Long Boy Drills	DSW-LB12RS-8	729.86
		1/2" Shank 18" Long Boy Drills	DSW-LB18RS-8	1071.88
		1/2" Shank Heavy Duty 135° S/Pt 12" Long Boy Drills	DSW-LBH12RS-8	793.56
		1/2" Shank Heavy Duty 135° S/Pt 18" Long Boy Drills	DSW-LBH18RS-8	1135.58
	11 PC SET Straight Shank 3/16 to 1/2 by 32nds Metal Stand	Straight Shank 18" Long Boy Drills	DSM-LB18-11	583.94
		Straight Shank Heavy Duty 135° S/Pt 18" Long Boy Drills	DSM-LBH18-11	612.16
	13 PC SET Straight Shank 1/8 to 1/2 by 32nds Metal Stand	Straight Shank 12" Long Boy Drills	DSM-LB12-13	342.18
		Straight Shank Heavy Duty 135° S/Pt 12" Long Boy Drills	DSM-LBH12-13	379.14
	25 PC SET Straight Shank 1/8 to 1/2 by 64ths Wood Stand	Straight Shank Bright Finish 12" Long Boy Drills	DSW-LB12-25	502.52

ILLUSTRATION	CONTENTS	TYPE OF DRILL	ITEM NO.	PRICE
 <p>ICS EXTRA LONG DRILLS</p>	<p>12 PC DRILL DISPLAY 12" AIRCRAFT EXTENSION DRILLS</p> <p>3 Ea. 1/8, 3/16, 1/4 1 Ea. 5/16, 3/8, 1/2</p> <p>Display Size: 12" x 18"</p>	Black Finish Aircraft Drills 135° S/Pt	DM-AC-12B-12	130.14

COMBINED DRILL & COUNTERSINK SETS

VINYL POUCH

ILLUSTRATION	CONTENTS	TYPE OF DRILL	ITEM NO.	PRICE
 <p>ICS</p>	<p>5 PC SET Sizes #1 to #5</p>	HSS - Plain - 60°	DS-CDC-5	21.18
		Titanium Nitride Coated - Plain - 60°	DS-CDCT-5	48.80
		Cobalt - Plain - 60°	DS-CDCC-5	60.04
Plain Type Combined Drills & Countersinks are designed to produce accurate center holes in components which require machining between centers				
	<p>5 PC SET Sizes #11 to #15 (Not Illustrated)</p>	HSS - Bell - 60°	DS-CDC-5B	25.00
		Bell Type Combined Drills & Countersinks are designed with an additional small 120° chamfer to protect the edges of the 60° hole.		

STEP DRILL SETS

WOOD STAND

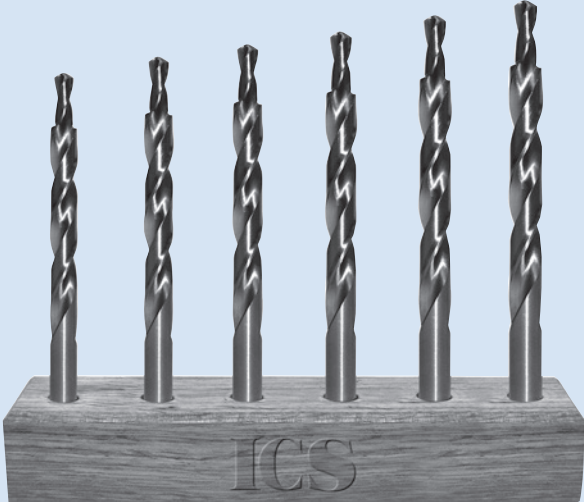
ILLUSTRATION	CONTENTS	ITEM NO.	PRICE
 <p>ICS</p>	<p>6 PC SET Jobber Length 45° #6 to 3/8</p>	SDJLS45-6	102.58
	<p>6 PC SET Jobber Length 82° #6 to 3/8</p>	SDJLS82-6	152.30
	<p>6 PC SET Jobber Length 90° #6 to 3/8</p>	SDJLS90-6	127.66
	Step Drill Sets contain #6 to 3/8 screw sizes and are available in 45°, 82°, and 90° step angles in jobber length and taper length drill styles.		

HIGH SPEED STEEL 9 PC SPOT WELD CUTTER SETS

METAL CASE

ILLUSTRATION	CONTENTS	ITEM NO.	PRICE	
	9 PC SET 1 hex shank 3/8" dia. spot weld cutter 5 extra replacement cutters 2 extra center pins 1 5/16" dia. cobalt spot weld drill	SWCS-HS-9	47.26	
	METRIC			
	9 PC SET - metric 1 hex shank 10mm dia. spot weld cutter 5 extra replacement cutters 2 extra center pins 1 8mm dia. cobalt spot weld drill	SWCS-HS-9M	47.26	
Spot Weld Cutter Sets are designed for the auto body repair trade for removing spot welds on thin sheet metal, aluminum, and other metals.				

HIGH SPEED STEEL ANNULAR (STRUCTURAL) CUTTER SETS

METAL INDEX

ILLUSTRATION	DEPTH OF CUT	STEEL SPECS	ITEM NO.	PRICE
7 PC SET 	7 PC CONTENTS			
	7/16, 9/16, 11/16, 13/16, 15/16, 1-1/16 and 1 Pilot Pin			
	1"	HIGH SPEED STEEL	AC1DS-7	235.84

PLASTIC CASE

ILLUSTRATION	DEPTH OF CUT	STEEL SPECS	ITEM NO.	PRICE
(6 PC SET PICTURED) 	6 PC CONTENTS			
	9/16, 11/16, 13/16, 15/16, 1-1/16 and 1 Pilot Pin			
	1"	HIGH SPEED STEEL	AC1DS-6	223.66
	2"	HIGH SPEED STEEL	AC2DS-6	515.56
	10 PC CONTENTS			
	1/2, 9/16, 5/8, 11/16, 3/4, 13/16, 7/8, 1 and 2 Pilot Pins			
	1"	HIGH SPEED STEEL	AC1DS-10	378.00
	12 PC CONTENTS			
	1/2, 9/16, 5/8, 11/16, 3/4, 13/16, 7/8, 15/16, 1, 1-1/16 and 2 Pilot Pins			
	2"	HIGH SPEED STEEL	AC2DS-12	611.12

HIGH SPEED STEEL PLASTIC & LAMINATE DRILL SETS

METAL INDEX

iLLUSTRATION	TYPE OF DRILLS	ITEM NO.	PRICE
7 PC DRILL SET 1/8 to 1/2 by 16ths 	SPECIAL POINT		
	Plastic Laminate Drills - Straight Shank Bright Finish - Special Point	DS-PLD-7	64.66
	Plastic Laminate Drills - 1/4" Shank Bright Finish - Special Point	DS-PLDQS-7	73.02
	Plastic Laminate Drills - 3/8" Shank Bright Finish - Special Point	DS-PLDTS-7	69.36
	60° POINT		
Plastic Laminate Drills - Straight Shank Bright Finish - 60° Point Drill	DS-PLB-7	67.96	

TOOL STEEL MULTI-ANGLE DRILL SETS

PLASTIC INDEX

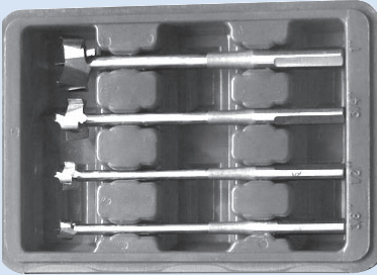
iLLUSTRATION	TYPE OF DRILL INDEX	ITEM NO.	PRICE
	4 pc Set (3/8, 1/2, 3/4, 1")	DS-MAD-4	31.50
	7 pc Set (3/8, 1/2, 5/8, 3/4, 7/8, 1", 1-1/4)	DS-MAD-7	58.80
	9 pc Set (1/4, 3/8, 1/2, 5/8, 3/4, 13/16, 7/8, 1", 1-1/4)	DS-MAD-9	88.20

CARBIDE TIPPED UNIVERSAL DRILL SET

METAL INDEX

iLLUSTRATION	CONTENTS	ITEM NO.	PRICE
	7 PC SET Universal Drill Set - Carbide Tipped 1/8, 3/16, 1/4, 5/16, 3/8, 7/16, 1/2	DS-CTUD-7	105.76
	Designed with a diamond ground special drill point for multi-purpose drilling. They are highly effective for drilling hard metals and alloys, reinforced concrete, stone, tile, ceramics, marble, granite, glass, hard and soft woods, plastics and many other difficult materials. Often used to drill out broken taps and hardened bolts.		

MASONRY HAMMER DRILL SETS - SDS SHANK

METAL CASE

CONTENTS (7 PC SET)	SHANK	ITEM NO.	PRICE
1 each: 3/16 x 4, 1/4 x 4; 2 each: 1/4 x 6; 1 each: 5/16 x 6, 3/8 x 6, 1/2 x 6	SDS Shank	MDS-SDS-7	97.74
1 each: 3/16 x 4, 1/4 x 4; 2 each: 1/4 x 6; 1 each: 5/16 x 6, 3/8 x 6, 1/2 x 6	Ramset Shank	MDS-RAM-7	106.56

WOOD (SPADE) BIT SET

VINYL POUCH

ILLUSTRATION	CONTENTS	ITEM NO.	PRICE
	6 PC SET 3/8, 1/2, 5/8, 3/4, 7/8, 1" 6" Wood Bits-Spade Type	WBS-WBS06L-6	14.36
	Designed for boring holes quickly through all types of hard and soft woods, including plywood. They perform best at high RPM speeds and are easy to sharpen. Fully polished and heat treated with six ground flats on 1/4" shank.		

TOOL STEEL FORSTNER BIT SETS

PLASTIC CASE

ILLUSTRATION	CONTENTS	ITEM NO.	PRICE
(8 PC SET PICTURED) 	8 PC SET 2-1/4 to 3-1/8 by 8ths	WBS-FB-08	280.88
	5 PC SET 3/4, 7/8, 1, 1-1/4, 1-5/8	WBS-FB-05	50.40
	7 PC SET 1/4 to 1" by 8ths	WBS-FB-07	47.26
	16 PC SET 1/4 to 2-1/8 by 8ths	WBS-FB-16	115.50
	24 PC SET 1/4 to 3-1/8 by 8ths	WBS-FB-24	252.28
Forstner bits are designed for intricate woodworking. They are used to drill flat bottom or through holes. Can bore any arc of a circle. Bit is guided by circular rim instead of center. Will cut satin smooth without deflection by grain or knots. Forstner bits are available machine ground to size from High Carbon Steel stock. Sizes 2-1/4" and over have multi-spur cutting edges.			

TOOL STEEL MULTI-SPUR PIPE BIT SETS

PLASTIC CASE

ILLUSTRATION	CONTENTS	ITEM NO.	PRICE
(4 PC SET PICTURED) 	4 PC SET 1-3/8, 1-1/2, 2-1/8, 2-9/16	WBS-MSPB-4	119.70
	8 PC SET 1", 1-1/8, 1-1/4, 1-3/8, 1-1/2, 1-3/4, 2, 2-1/8	WBS-MSPB-8	241.50
Beveled saw teeth allow smooth boring of holes. Inside cutter pushes chips to rear of bit, allowing deep holes to be bored without clogging. Ideal for plumbing and electrical work.			

WOOD (BRAD POINT) DRILLS SETS

SPECIAL PURPOSE

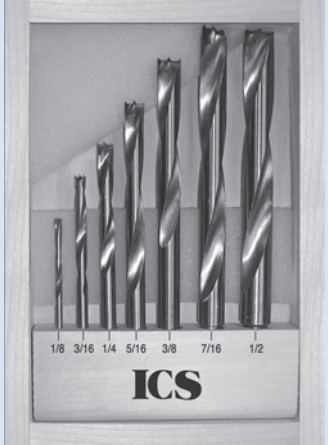
ILLUSTRATION	CONTENTS	ITEM NO.	PRICE
	High Speed Steel 7 PC SET - 1/8 to 1/2 by 16ths	DS-WDBP-7	35.16
	High Speed Steel - Carbide Tipped 7 PC SET - 1/8 to 1/2 by 16ths	DS-CTWDBP-7	55.42
<p>Designed to drill smooth, accurate holes in wood with minimum tear-out. Center spur point holds drill on target and prevents walking when two cutting spurs make contact with a surface, so even overlapping holes can be drilled. Drills are made of chrome vanadium steel and will stay sharp much longer than high carbon tool steels.</p>			

PERFECT POINT WOOD DRILL SETS

METAL INDEX

ILLUSTRATION	CONTENTS	SHANK	ITEM NO.	PRICE
 <p>(7 PC SET PICTURED)</p>	JOBBER LENGTH			
	Bright Finish Perfect Pt. Wood Drills 7 PC SET - 1/8 to 1/2 by 16ths	Straight	DS-PPWD-7	64.66
	Bright Finish Perfect Pt. Wood Drills 7 PC SET - 1/8 to 1/2 by 16ths	3/8	DS-PPWDTS-7	69.36
	SILVER & DEMING - 1/2" SHANK			
	Dual Finish Perfect Pt. Wood Drills 8 PC SET - 9/16 to 1" by 16ths	1/2	DS-PPWDRS-8	307.28
	<p>Perfect Point ® Wood Drills are designed to drill perfectly round, clean, flat bottom holes or through holes without splintering or tearing wood grain surface. They are unique in that they do not tear wood grain when breaking through exit side of hole. They outperform and last three to five times longer than Brad Point Drills, Dowel Drills, and Forstner Bits.</p>			

TAPER POINT DRILL SET

VINYL POUCH

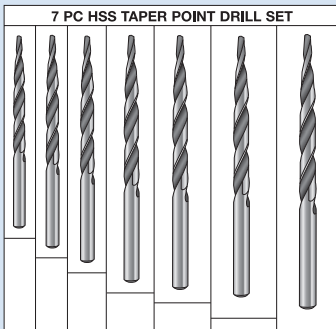
DESCRIPTION	CONTENTS	ITEM NO.	PRICE
7 PC Taper Point Drill Set 	1 each: 1/8, 9/64, 5/32, 11/64, 3/16, 7/32, 1/4 Taper Point Drills Regular Length	DS-TPDRL-7	19.42

INTERCHANGEABLE PILOT COUNTERBORE SET

WOOD BOX

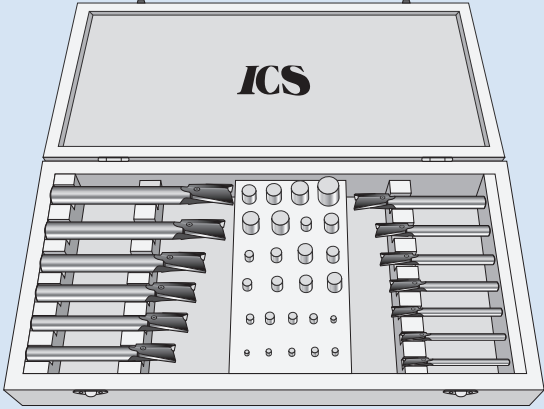
DESCRIPTION	CONTENTS	ITEM NO.	PRICE
	39 PC SET Straight Shank - 1/4 to 1" by 16ths Interchangeable Pilots 1/8, 5/32, 3/16, 1/4 with 3/32 Shank 3/16, 7/32, 1/4, 9/32, 5/16 with 5/32 Shank 1/4, 5/16, 3/8, 7/16, 1/2 with 3/16 Shank 5/16, 3/8, 7/16, 1/2, 9/16, 5/8 with 1/4 Shank 3/8, 7/16, 1/2, 9/16, 5/8, 3/4 with 5/16 Shank	CS-ICP-39	538.12
	Designed to create a recess for a cap screw, spring or bolt. They are used with interchangeable pilots ground to fit various hole sizes to be counterbored.		

CAP SCREW COUNTERBORE SETS

WOOD STAND

DESCRIPTION	CONTENTS	ITEM NO.	PRICE
CAP SCREW COUNTERBORE SET	4 PC SET 3 Flute - Straight Shank #8, #10, 1/4, 3/8	CS-CSC3F-4	105.84
METRIC CAP SCREW COUNTERBORE SET	7 PC SET 3 Flute - Straight Shank M3, M4, M5, M6, M8, M10, M12	CS-CSC3FM-7	282.98

FILLISTER HEAD SCREW COUNTERBORE SETS

WOOD STAND

DESCRIPTION	CONTENTS	ITEM NO.	PRICE
FILLISTER HEAD COUNTERBORE SETS	5 PC SET 2 Flute - Straight Shank #2, #4, #6, #8, #10	CS-FHSC-5	75.26
	4 PC SET 2 Flute - Straight Shank 1/4, 5/16, 3/8, 1/2	CS-FHSC-4	129.36

HIGH SPEED STEEL COUNTERSINK SETS

WOOD STANDS

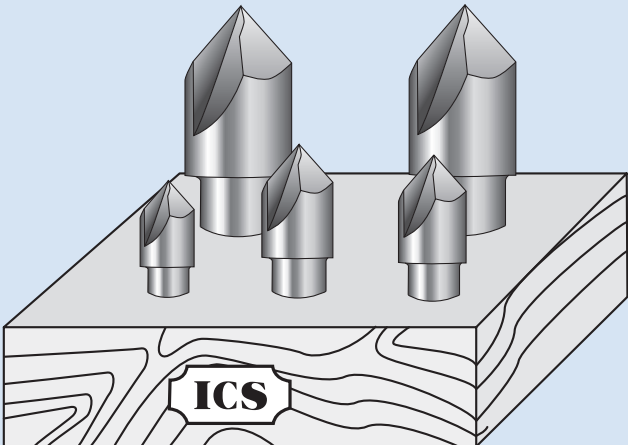
DESCRIPTION	ITEM NO.	INCLUDED ANGLE	PRICE
<div style="text-align: center;">  <p>5 PC COUNTERSINK SETS</p> </div> <div style="margin-top: 20px;"> <p>SIZES IN SETS</p> <p>1/4", 3/8", 1/2", 5/8", 3/4" —————</p> <p>1/2", 5/8", 3/4", 7/8", 1 —————</p> <p>#0, 1, 2, 3, 4 —————</p> <p>Custom sets are available Inquire for pricing.</p> </div>	SINGLE FLUTE		
	→ CSKS160-5	60°	82.28
	CSKS182-5	82°	82.28
	CSKS190-5	90°	82.28
	CSKS100-5	100°	82.28
	CSKS110-5	110°	82.28
	CSKS120-5	120°	82.28
	THREE FLUTE (CENTER REAMER)		
	CSKS360-5	60°	82.28
	CSKS382-5	82°	82.28
	CSKS390-5	90°	82.28
	CSKS300-5	100°	82.28
	CSKS310-5	110°	82.28
	CSKS320-5	120°	82.28
	SIX FLUTE (CHATTERLESS)		
	CSKS660-5	60°	96.38
	CSKS682-5	82°	96.38
	CSKS690-5	90°	96.38
	CSKS600-5	100°	96.38
	→ CSKS620-5	120°	96.38
	FOUR FLUTE (MACHINE)		
	→ CSKS460-5	60°	197.70
	→ CSKS482-5	82°	197.70
	→ CSKS490-5	90°	197.70
	ZERO FLUTE (DEBURRING)		
→ CSKS060-5	60°	80.40	
→ CSKS082-5	82°	80.40	
→ CSKS090-5	90°	80.40	

COMBINED DRILL & COUNTERSINK SETS

VINYL POUCH

ILLUSTRATION	DESCRIPTION	TYPE OF DRILL	ITEM NO.	PRICE	
<div style="text-align: center;">  <p>ICS</p> </div>	<p>5 PC SET Sizes #1 to #5</p>	HSS - Plain - 60°	DS-CDC-5	21.18	
		Titanium Nitride Coated - Plain - 60°	DS-CDCT-5	48.80	
		Cobalt - Plain - 60°	DS-CDCC-5	60.04	
	Plain Type Combined Drills & Countersinks are designed to produce accurate center holes in components which require machining between centers				
	<p>5 PC SET Sizes #11 to #15</p>	HSS - Bell - 60°	DS-CDC-5B	25.00	
Bell Type Combined Drills & Countersinks are designed with an additional small 120° chamfer to protect the edges of the 60° hole.					

CARBIDE INSERT INDEXABLE COUNTERSINK SETS

WOOD CASE

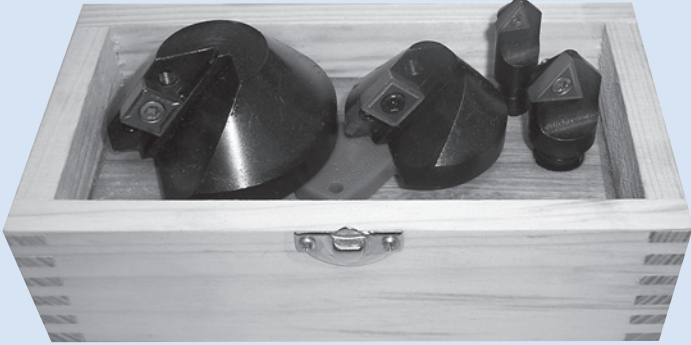
ILLUSTRATION	CONTENTS	POINT ANGLE	ITEM NO.	PRICE
 <p>(4 PC SET PICTURED)</p>	4 PC SET	60°	ICSKS060-4	199.60
	1/2, 3/4,	82°	ICSKS082-4	199.60
	1-3/4, 2-1/2	90°	ICSKS090-4	199.60
	3 PC SET	60°	ICSKS060-3	163.16
	3/4, 1-3/4, 2-1/2	82°	ICSKS082-3	163.16
		90°	ICSKS090-3	163.16
	<p>Designed with a positive rake for smooth cutting without chatter. No tool resharpening needed. Uses standard square or triangle inserts that come with countersink.</p>			

HIGH SPEED STEEL 1/2" SHANK SILVER & DEMING REAMER SETS

ICS WIS PLASTIC CASE

ILLUSTRATION	CONTENTS	SHANK	ITEM NO.	PRICE
 <p>(6 PC SET PICTURED)</p>	STRAIGHT FLUTE			
	6 PC SET			
	5/8, 11/16, 3/4, 13/16, 7/8, 1"	1/2"	RS-CRSFRS6L-6	369.14
	Straight Flute			
	4 PC SET			
	1-1/8, 1-1/4, 1-3/8, 1-1/2	1/2"	RS-CRSFRS6L-4	534.08
	Straight Flute			
	HELICAL FLUTE			
6 PC SET				
5/8, 11/16, 3/4, 13/16, 7/8, 1"	1/2"	RS-CRHFRS6L-6	414.06	
Helical Flute				
4 PC SET				
1-1/8, 1-1/4, 1-3/8, 1-1/2	1/2"	RS-CRHFRS6L-4	595.60	
Helical Flute				

HIGH SPEED STEEL CHUCKING REAMER SETS

STRAIGHT
SHANK

METAL INDEX

STRAIGHT
FLUTE

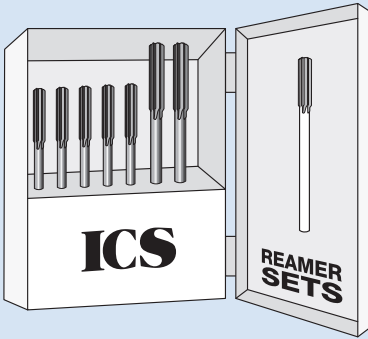
ILLUSTRATION	CONTENTS	FLUTE	SHANK	ITEM NO.	PRICE
	14 PC SET Dowel Pin Sizes .1230 to .4995	Straight	Straight	RS-CRSFDP-14	321.54
	14 PC SET Over & Under Sizes .1240 to .5010	Straight	Straight	RS-CRSFOU-14	321.16
	26 PC SET Letter Sizes A to Z	Straight	Straight	RS-CRSF-26	523.78
	29 PC SET Sizes 1/16 to 1/2 by 64ths	Straight	Straight	RS-CRSF-29	489.86
	60 PC SET Wire Gauge Sizes 1 to 60	Straight	Straight	RS-CRSF-60	733.96
Designed for general purpose reaming of most ferrous and non-ferrous metals. The cutting edge is ground with a 45° chamfer angle for easy hole entry.					

HIGH SPEED STEEL JOBBER REAMER SET - TAPER SHANK

ICS WIS

PLASTIC CASE

RIGHT HAND CUT

CONTENTS	SHANK	ITEM NO.	PRICE
10 PC SET 15/16, 1, 1-1/16, 1-1/8, 1-3/16 1-1/4, 1-5/16, 1-3/8, 1-7/16, 1-1/2	Taper	RS-TSJRSF-10	2649.96

HIGH SPEED STEEL TAPER PIN REAMER SETS

ICS WIS

PLASTIC CASE

RIGHT HAND CUT

CONTENTS	FLUTE	ITEM NO.	PRICE
11 PC SET #0, #1, #2, #3, #4, #5, #6, #7, #8, #9, #10	Straight Flute	RS-TPRSF-11	-
	Spiral Flute	RS-TPRSP-11	411.40
	Helical	RS-TPRHF-11	-

HIGH SPEED STEEL AUTOMOTIVE STEERING AND SUSPENSION REAMER SET

ICS WIS

PLASTIC CASE

RIGHT HAND CUT

ILLUSTRATION	CONTENTS	ITEM NO.	PRICE
(2 PC SET PICTURED) 	2 PC SET .4375, .7500 (7/16) (3/4)	RS-ASSR-2	237.34
	3 PC SET .4375, .7500, .9375 (7/16) (3/4) (15/16)	RS-ASSR-3	399.94
	4 PC SET .4375, .7500, .9375, .3750 (7/16) (3/4) (15/16) (3/8)	RS-ASSR-4	518.28
	5 PC SET .4375, .7500, .9375, .3750, .4370 (7/16) (3/4) (15/16) (3/8) (11.1mm)	RS-ASSR-5	593.78

ADJUSTABLE HAND REAMER SETS

ICS

WIS

PLASTIC CASE

RIGHT HAND CUT

ILLUSTRATION	CONTENTS	ITEM NO.	PRICE
<p>(11 PC SET PICTURED)</p> 	4 PC SET 8A to 5A	RS-AHR-4	232.42
	8 PC SET A to H	RS-AHR-8	559.08
	11 PC SET A to K	RS-AHR-11	839.08
Designed with enough of an adjustment range to ream almost any odd size hole encountered in reaming. The blades are made of high speed steel for long life and can be adjusted by loosening one nut while tightening the other. They are used mostly for repair work in the field.			

* Custom sets can be made per customer requirements. Inquire for pricing.

LONG PILOT ADJUSTABLE HAND REAMER SETS

ICS

WIS

PLASTIC CASE

RIGHT HAND CUT

ILLUSTRATION	CONTENTS	ITEM NO.	PRICE
<p>(8 PC SET PICTURED)</p> 	4 PC SET 8A to 5A	RS-LPAHR-4	480.34
	8 PC SET A to H	RS-LPAHR-8	983.28
	11 PC SET A to K	RS-LPAHR-11	1605.40
Designed for in line reaming when two holes are spaced far apart. The solid ground pilot uses a "floating" tapered guide sleeve which is seated in one hole to guide the reamer as it reams the other hole. The tapered guide sleeve can be used at either end of the other hole.			

* Custom sets can be made per customer requirements. Inquire for pricing.

TOWER BOLT REAMER SET

DESCRIPTION	CONTENTS	ITEM NO.	PRICE
	3 PC SET 9/16, 11/16, 13/16	TBR3-3	181.90
Designed for lining up bolt holes on cell phone towers, wind mills, and transmission towers. They have three flats on the shank for use in 1/2" three jaw power tools and pneumatic equipment. The extra short length makes them more useful in close quarters.			

SCREW EXTRACTOR SETS

PLASTIC CASE

ILLUSTRATION	CONTENTS	TYPE	ITEM NO.	PRICE
 <p>(9 PC SET PICTURED)</p>	Sizes #1 to #9	Helical Flute - Round Shank	SXS-HF-9	100.56
	Sizes #1 to #7		SXS-HF-07	30.00
	Sizes #1 to #6		SXS-HF-06	26.80
	Sizes #1 to #7	Straight Flute - Straight Shank	SXS-SF-07	44.04
Used to remove broken screws, bolts, studs, pipe, and lubrication fittings without damage to the threaded hole.				
VINYL POUCH				
5 PC SCREW EXTRACTOR SET (VINYL POUCH)	5 PC SET • #1 to #5	Helical Flute - Round Shank	SXS-HF-5	12.28
	5 PC SET • #1 to #5	Straight Flute - Square Shank	SXS-SF-5	15.40
	5 PC SET • #1 to #5	Straight Flute - Round Shank	SXS-SFR-5	17.34

SCREW EXTRACTOR AND DRILL SETS

METAL CASE

CONTENTS	TYPE OF SCREW EXTRACTOR & DRILLS	ITEM NO.	PRICE
10 PC SCREW EXTRACTOR SET One each Sizes #1 to #5 Screw Extractors One each 5/64, 7/64, 5/32, 1/4, 19/64 Screw Machine Drills with RH or LH cut	Helical Flute Screw Extractors Screw Machine Drills - RH cut	SXDS-10	23.52
	Helical Flute Screw Extractors Screw Machine Drills - LH cut	SXDS-10L	36.50

10 PC MULTI-SPLINE SCREW EXTRACTOR SET

PLASTIC CASE

ILLUSTRATION	CONTENTS	ITEM NO.	PRICE
	10 PC SET 1/8, 5/32, 3/16, 7/32, 1/4, 9/32, 5/16, 11/32, 3/8, 13/32	MSSXS-10	32.30
	Used to remove broken studs, bolts, socket screws, and lubrication fittings. They are designed with an aggressive left hand spiral design for maximum gripping power and can be used with a socket or flat wrench.		
MULTI-SPLINE SCREW EXTRACTOR		FOR BOLT SIZE	MULTI-SPLINE SCREW EXTRACTOR FOR BOLT SIZE
	1/8	#12	9/32
	5/32	1/4	5/16
	3/16	5/16	11/32
	7/32	3/8	3/8
	1/4	7/16	13/32
			1/2
			9/16
			5/8
			11/16
			3/4

10 PC BOLT AND NUT EXTRACTOR SET

ALUMINUM CASE

Hex Head Bolt and Nut Extractors are used for removing damaged fasteners and rounded-off hex bolts and nuts. They are designed with a reverse spiral flute to grip a damaged fastener as you turn the tool and they can be used with most wrenches or a ratchet socket. They will remove both metric and inch size fasteners from 9-19mm or 3/8" to 3/4".

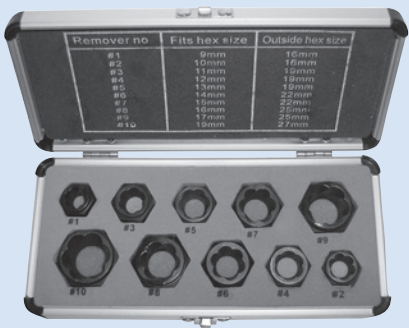
ILLUSTRATION	CONTENTS				ITEM NO.	PRICE
	10 PC SET Sizes #1 to #10				BNXS-10M	32.56
	BOLT & NUT EXTRACTOR	FITS HEX SIZE	BOLT & NUT EXTRACTOR	FITS HEX SIZE		
	#1	9mm 3/8	#6	14mm 9/16		
#2	10mm	#7	15mm			
#3	11mm 7/16	#8	16mm 5/8			
#4	12mm	#9	17mm			
#5	13mm 1/2	#10	19mm 3/4			

10 PC BROKEN TAP EXTRACTOR SET

ICS WIS

PLASTIC CASE

ICS Broken Tap Extractors are used to remove broken taps without damage to the threaded hole. They have hardened steel fingers to fit in the flutes of a broken tap to turn it out safely, and can be used with a socket or tap wrench.

ILLUSTRATION	DESCRIPTION		ITEM NO.	PRICE		
	10 PC SET Sizes #1 to #10		BTXS-10	51.24		
	TAP EXTRACTOR	FOR TAP SIZE			NO. OF FLUTES	
	SIZE	INCH			METRIC	
#1	#6	4mm	3			
#2	#8-10	5mm	3			
#3	1/4	6mm	4			
#4	5/16	8mm	4			
#5	3/8	10mm	4			
#6	1/2	12mm	4			
#7	9/16	14mm	4			
#8	5/8	16mm	4			
#9	3/4	18-20mm	4			
#10	7/8	22mm	4			

CARBON STEEL - HIGH SPEED STEEL TAPER PIPE TAP SETS

GENERAL PURPOSE

6 Piece High Speed and Carbon Steel American National Standard Pipe Thread Tap Sets are available in NPT, NPTF, NPS, NPSF, NPT-Interrupted, and NPT-Left hand thread forms. They are made to ANSI B1.20.1-1983 tap dimensions.

ILLUSTRATION	DESCRIPTION	STEEL SPEC	CUT	THREAD FORM	ITEM NO.	PRICE
	6 PC Pipe Tap Set available in hinged wooden case or industrial plastic case. Contents of set is listed below.	CS	Right Hand	Taper	TS-CNPT-6	151.06
		HSS	Right Hand	Taper	TS-NPT-6	292.56
		HSS	Right Hand	Interrupted	TS-NPTI-6	381.02
		HSS	Right Hand	Straight	TS-NPS-6	311.90
		HSS	Left Hand	Reg. Taper	TS-NPTL-6	488.02
CONTENTS						
American – 1/8-27, 1/4-18, 3/8-18, 1/2-14, 3/4-14, 1-11-1/2						

CARBON STEEL - HIGH SPEED STEEL BRITISH STANDARD PIPE TAP SETS

GENERAL PURPOSE

6 Piece High Speed and Carbon Steel British Standard Pipe Thread Tap Sets are available in BSPT and BSPF thread forms. They are made to BS2779-ISO529 tap dimensions.

ILLUSTRATION	DESCRIPTION	STEEL SPEC	CUT	THREAD FORM	ITEM NO.	PRICE
	6 PC Pipe Tap Set available in hinged wooden case or industrial plastic case. Contents of set is listed below.	CS	Right Hand	Reg. Taper	TS-CBSPT-6	162.12
		HSS	Right Hand	Reg. Taper	TS-BSPT-6	553.76
		HSS	Right Hand	Parallel	TS-BSPP-6	553.76
CONTENTS						
British – 1/8-28, 1/4-19, 3/8-19, 1/2-14, 3/4-14, 1-11						

TOOL STEEL HEXAGON RETHREADING DIE SETS

WOODEN CASES

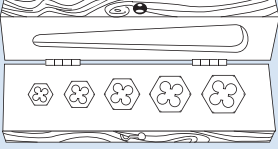
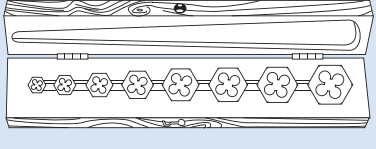
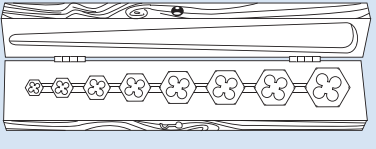
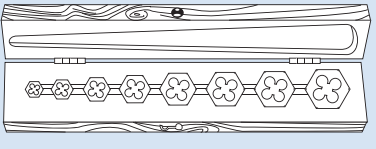
ILLUSTRATION	DESCRIPTION	CUT	THREAD TYPE	ITEM NO.	PRICE
 <p>5 PC HEX DIE SET</p>	5 PC Hex Die Set in a hinged wooden case.	Right Hand	Coarse	DS-HRD-5C	84.80
	Contents of NC, NF, and Metric sets are listed below. (Specify style required.)	Right Hand	Fine	DS-HRD-5F	84.80
		Left Hand	Coarse	DS-HRDL-5C	103.16
<p>SIZES: 1/4 to 1/2 or M6 to M14</p>		Left Hand	Fine	DS-HRDL-5F	103.16
		Right Hand	Metric	DS-HRDM-5C	106.66
		SIZES OF DIES IN 5 PC SET			
	NC (Coarse) 1/4-20, 5/16-18, 3/8-16, 7/16-14, 1/2-13				
	NF (Fine) 1/4-28, 5/16-24, 3/8-24, 7/16-20, 1/2-20				
	M (Metric) M6.0 x 1.0, M8.0 x 1.25, M10.0 x 1.5, M12.0 x 1.75, M14.0 x 2.0				
 <p>8 PC HEX DIE SET</p>	8 PC Hex Die Set in a hinged wooden case.	Right Hand	Coarse	DS-HRD-8C	127.74
	Contents of NC, NF, and Metric sets are listed below. (Specify style required.)	Right Hand	Fine	DS-HRD-8F	127.74
		Left Hand	Coarse	DS-HRDL-8C	163.20
<p>SIZES: 1/4 to 3/4 or M6 to M20</p>		Left Hand	Fine	DS-HRDL-8F	163.20
		Right Hand	Metric	DS-HRDM-8C	172.08
		SIZES OF DIES IN 8 PC SET			
	NC (Coarse) 1/4-20, 5/16-18, 3/8-16, 7/16-14, 1/2-13, 9/16-12, 5/8-11, 3/4-10				
	NF (Fine) 1/4-28, 5/16-24, 3/8-24, 7/16-20, 1/2-20, 9/16-18, 5/8-18, 3/4-16				
	M (Metric) M6.0 x 1.0, M8.0 x 1.25, M10.0 x 1.5, M12.0 x 1.75, M14.0 x 2.0, M16.0 x 2.0, M18.0 x 2.5, M20.0 x 2.5				
 <p>10 PC HEX DIE SET</p>	10 PC Hex Die Set in a hinged wooden case.	Right Hand	Coarse	DS-HRD-10C	121.12
	Contents of NC, NF, and Metric sets are listed below. (Specify style required.)	Right Hand	Fine	DS-HRD-10F	121.12
		Left Hand	Coarse	DS-HRDL-10C	243.74
<p>SIZES: 1/4 to 1 or M6 to M24</p>		Left Hand	Fine	DS-HRDL-10F	243.74
		Right Hand	Metric	DS-HRDM-10C	241.42
		SIZES OF DIES IN 10 PC SET			
	NC (Coarse) 1/4-20, 5/16-18, 3/8-16, 7/16-14, 1/2-13, 9/16-12, 5/8-11, 3/4-10, 7/8-9, 1-8				
	NF (Fine) 1/4-28, 5/16-24, 3/8-24, 7/16-20, 1/2-20, 9/16-18, 5/8-11, 3/4-16, 7/8-14, 1-14				
	M (Metric) M6.0 x 1.0, M8.0 x 1.25, M10.0 x 1.5, M12.0 x 1.75, M14.0 x 2.0, M16.0 x 2.0, M18.0 x 2.5, M20.0 x 2.5, M22.0 x 2.5, M24.0 x 3.0				
 <p>4 PC HEX DIE SET</p>	4 PC Hex Die Set in a hinged wooden case.	Right Hand	Coarse	DS-HRD-4C	140.70
	Contents of NC, NF, and Metric sets are listed below. (Specify style required.)	Right Hand	Fine	DS-HRD-4F	140.70
		Left Hand	Coarse	DS-HRDL-4C	319.48
<p>SIZES: 1-1/8 to 1-1/2 or M27 to M36</p>		Left Hand	Fine	DS-HRDL-4F	319.48
		Right Hand	Metric	DS-HRDM-4C	233.76
		SIZES OF DIES IN 4 PC SET			
	NC (Coarse) 1-1/8-7, 1-1/4-7, 1-3/8-6, 1-1/2-6				
	NF (Fine) 1-1/8-12, 1-1/4-12, 1-3/8-12, 1-1/2-12				
	M (Metric) M27.0 x 3.0, M30.0 x 3.5, M33.0 x 3.5, M36.0 x 4.0				

HEXAGON RETHREADING PIPE DIE SET

PLASTIC CASE

ILLUSTRATION	DESCRIPTION	CUT	THREAD TYPE	ITEM NO.	PRICE
 <p>6 PC NPT PIPE NPT HEX DIE SET</p>	<p>6 PC Hex Pipe NPT Dies in a hinged wooden case. Contents of NPT set is listed below. wt. 5lbs.</p>	Taper	Regular	DS-HRDP-6	168.00
<p>NPT (Regular Taper) 1/8-27, 1/4-18, 3/8-18, 1/2-14, 3/4-14, 1-11-1/2</p>					

CARBON STEEL / HIGH SPEED STEEL 12 PC PIPE TAP AND HEXAGON DIE SETS

PLASTIC CASE

12 Piece High Speed/Carbon Steel NPT Pipe Tap & Hex Die Sets are designed to repair damaged NPT pipe threads. Sets come in a deluxe black plastic carrying case. Each 12 piece set contains one NPT Pipe Tap and NPT Hex Die in the following sizes: 1/8 - 27, 1/4 - 18, 3/8 - 18, 1/2 - 14, 3/4 - 14, and 1 - 11-1/2.

ILLUSTRATION	DESCRIPTION	CUT	ITEM NO.	PRICE
 <p>12 PC NPT PIPE TAP & HEX DIE SET</p>	<p>Each set contains one each NPT Pipe Tap & Hex Die in your choice of either carbon steel, high speed steel or a combination of high speed steel taps and carbon steel hex dies.</p>	Right Hand	THDS-CS-12NPT Carbon Steel Taps/Dies	207.90
		Right Hand	THDS-HS-12NPT HSS Taps/Dies	563.80
		Right Hand	THDS-HSC-12NPT HSS Taps Carbon Steel Dies	380.10
		SIZES OF NPT PIPE TAPS & HEX DIES		
<p>1/8 - 27, 1/4 - 18, 3/8 - 18, 1/2 - 14, 3/4 - 14, 1 - 11-1/2</p>				

Sizes: 1/8" - 1"

Note: Carbon Steel Taps are for rethreading only. HSS taps and dies can be used for rethreading and cutting new threads with taps.

HEXAGON THREADING DIE SETS

WOODEN CASES

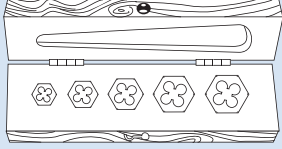
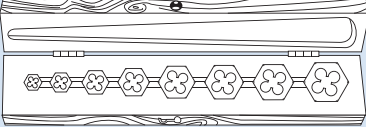
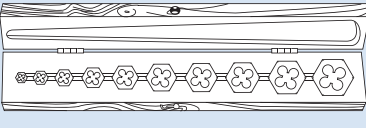
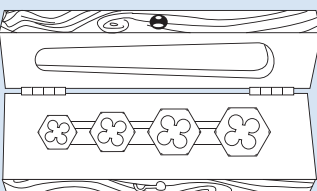
ILLUSTRATION	DESCRIPTION	CUT	THREAD TYPE	ITEM NO.	PRICE
5 PC HSS HEX DIE SET  SIZES: 1/4 to 1/2	5 PC Hex Die Set in a hinged wooden case. Contents of NC, NF, and Metric sets are listed below. (Specify style required.) Black & Gold finish.	Right Hand Right Hand	Coarse Fine	DS-HTD-5C DS-HTD-5F	131.28 131.28
	SIZES OF HIGH SPEED STEEL DIES IN 5 PC SET				
	NC (Coarse) 1/4-20, 5/16-18, 3/8-16, 7/16-14, 1/2-13 NF (Fine) 1/4-28, 5/16-24, 3/8-24, 7/16-20, 1/2-20				
8 PC HSS HEX DIE SET  SIZES: 1/4 to 3/4	8 PC Hex Die Set in a hinged wooden case. Contents of NC, NF, and Metric sets are listed below. (Specify style required.) Black & Gold finish.	Right Hand Right Hand	Coarse Fine	DS-HTD-8C DS-HTD-8F	223.54 223.54
	SIZES OF HIGH SPEED STEEL DIES IN 8 PC SET				
	NC (Coarse) 1/4-20, 5/16-18, 3/8-16, 7/16-14, 1/2-13, 9/16-12, 5/8-11, 3/4-10 NF (Fine) 1/4-28, 5/16-24, 3/8-24, 7/16-20, 1/2-20, 9/16-18, 5/8-18, 3/4-16				
10 PC HSS HEX DIE SET  SIZES: 1/4 to 1	10 PC Hex Die Set in a hinged wooden case. Contents of NC, NF, and Metric sets are listed below. (Specify style required.) Black & Gold finish.	Right Hand Right Hand	Coarse Fine	DS-HTD-10C DS-HTD-10F	328.24 328.24
	SIZES OF HIGH SPEED STEEL DIES IN 10 PC SET				
	NC (Coarse) 1/4-20, 5/16-18, 3/8-16, 7/16-14, 1/2-13, 9/16-12, 5/8-11, 3/4-10, 7/8-9, 1-8 NF (Fine) 1/4-28, 5/16-24, 3/8-24, 7/16-20, 1/2-20, 9/16-18, 5/8-11, 3/4-16, 7/8-14, 1-14				
4 PC HSS HEX DIE SET  SIZES: 1-1/8 to 1-1/2	4 PC Hex Die Set in a hinged wooden case. Contents of NC, NF, and Metric sets are listed below. (Specify style required.) Black & Gold finish.	Right Hand Right Hand	Coarse Fine	DS-HTD-4C DS-HTD-4F	465.26 465.26
	SIZES OF HIGH SPEED STEEL DIES IN 4 PC SET				
	NC (Coarse) 1-1/8-7, 1-1/4-7, 1-3/8-6, 1-1/2-6 NF (Fine) 1-1/8-12, 1-1/4-12, 1-3/8-12, 1-1/2-12				

NOTE: Special boxed sets can be made to your requirements.

40 PC TAP AND HEX DIE SETS

METAL CASES

ILLUSTRATION	DESCRIPTION	STEEL SPEC	CUT	THREAD TYPE	ITEM NO.	PRICE
	40 PC Tap and Hex Die Set in plastic case. Each set contains one each NC and NF Plug Tap and Hexagon Die. Sizes are listed below. Set also includes 1/8-27 NPT Pipe Tap and 6 threading tools.	CS	Right Hand	NC, NF NPT	THDS-CS-40	181.60
		HSS	Right Hand	NC, NF NPT	THDS-HS-40	233.98
SIZES OF TAPS AND HEX DIES IN SET						
NC (Coarse) #4-40, #6-32, #8-32, #10-24, #12-24, 1/4-20, 5/16-18, 3/8-16, 7/16-14, 1/2-13 NF (Fine) #10-32, 1/4-28, 5/16-24, 3/8-24, 7/16-20, 1/2-20 NPT (Regular Taper) 1/8-27						
THREADING TOOLS IN SET						
Adjustable Die Stock - 1" round or hex T-Handle Tap Wrench - #0 to 1/4" Adjustable Tap Wrench - #4 to 1/2" T-Handle Tap Wrench - 1/4" to 1/2" Screw Pitch Gauge - Fractional #5 Screwdriver						

40 PC METRIC TAP AND HEX DIE SET

METAL CASES

ILLUSTRATION	DESCRIPTION	STEEL SPEC	CUT	THREAD TYPE	ITEM NO.	PRICE
	40 PC Tap and Hex Die Set in plastic case. Each set contains one each NC and NF Plug Tap and Hexagon Die. Sizes are listed below. Set also includes 1/8-28 BSPT Pipe Tap and 6 threading tools.	CS	Right Hand	NC, NF BSPT	THDS-CS-40M	189.24
		SIZES OF TAPS AND HEX DIES IN SET				
NC (Coarse) M3.0 x .50, M4.0 x .70, M5.0 x .80, M6.0 x 1.0, M7.0 x 1.0, M8.0 x 1.25 M9.0 x 1.25, M10.0 x 1.50, M11.0 x 1.50, M12.0 x 1.75 NF (Fine) M3.0 x .60, M4.0 x .75, M5.0 x .90, M9.0 x 1.00, M10.0 x 1.25, M12.0 x 1.50 BSPT (British Standard) 1/8-28						
THREADING TOOLS IN SET						
Adjustable Die Stock - 1" round or hex T-Handle Tap Wrench - M3 to M6 Adjustable Tap Wrench - M3 to M12 T-Handle Tap Wrench - M6 to M12 Screw Pitch Gauge - Metric #5 Screwdriver						

58 PC TAP AND HEX DIE SETS

METAL CASES

58 Piece Tap and Die Sets were originally designed to be a more advanced general purpose tap and die set for mechanics and DIY'ers for maintenance on domestic cars, motorcycles, and machinery that were manufactured using the unified inch thread standard. Each set contains the most popular sizes (#6-32 to 3/4-16) sizes that mechanics commonly use. Double layer metal case has individual compartments for tap and die storage and easy access.

ILLUSTRATION	DESCRIPTION	STEEL SPEC	CUT	THREAD TYPE	ITEM NO.	PRICE
 <p>SIZES #6 TO 3/4"</p>	Each set contains one each NC and NF Plug Tap and Hexagon Die in your choice of either Carbon Steel, High Speed Steel, or a combination (High Speed Steel Taps and Carbon Steel Hexagon Dies).	CS	Right Hand	NC, NF NPT	THDS-CS-58	381.02
		HSS	Right Hand	NC, NF NPT	THDS-HS-58	778.52
		HSS & CS	Right Hand	NC, NF NPT	THDS-HS/C-58	558.60
SIZES OF TAPS AND HEX DIES IN SET						
NC (Coarse) #6-32, #8-32, #10-24, #12-24, 1/4-20, 5/16-18, 3/8-16, 7/16-14, 1/2-13, 9/16-12, 5/8-11, 3/4-10						
NF (Fine) #10-32, 1/4-28, 5/16-24, 3/8-24, 7/16-20, 1/2-20, 9/16-18, 5/8-18, 3/4-16						
NPT (Regular Taper) 1/8-27, 1/4-18						
THREADING TOOLS IN SET						
Adjustable Tap Wrench - #4 to 1/2"			T-Handle Tap Wrench - #0 - 1/4"			
Adjustable Tap Wrench - 1/4 to 3/4"			Screw Pitch Gauge - Fractional			
Die Stock - 1" Round or Hex			Screwdriver - 1/8" x 2-1/4" Pocket Clip			
Die Stock - 1-1/2" Round or 1-7/16" Hex			Screw Extractors - Spiral Flute -#1 to 5			

65 PC TAP AND HEX DIE SETS

PLASTIC CASES

65 Piece Tap and Die Sets were originally designed to be a professional general purpose tap and die set for mechanics and DIY'ers for maintenance on domestic cars, motorcycles, and machinery that were manufactured using the unified inch thread standard. Each set contains the most popular sizes (#4-40 to 1-14) sizes that mechanics commonly use. Plastic case has individual compartments for tap and die storage and easy access.

ILLUSTRATION	DESCRIPTION	STEEL SPEC	CUT	THREAD TYPE	ITEM NO.	PRICE
 <p>SIZES #4 TO 1"</p>	Each set contains one each NC and NF Plug Tap and Hexagon Die in your choice of either Carbon Steel, High Speed Steel, or a combination (High Speed Steel Taps and Carbon Steel Hexagon Dies).	CS	Right Hand	NC, NF NPT	THDS-CS-65	651.50
		HSS	Right Hand	NC, NF NPT	THDS-HS-65	1131.32
		HSS & CS	Right Hand	NC, NF NPT	THDS-HS/C-65	970.20
SIZES OF TAPS AND HEX DIES IN SET						
NC (Coarse) #4-40, #6-32, #8-32, #10-24, #12-24, 1/4-20, 5/16-18, 3/8-16, 7/16-14, 1/2-13, 9/16-12, 5/8-11, 3/4-10, *7/8-9, *1-8						
NF (Fine) #10-32, 1/4-28, 5/16-24, 3/8-24, 7/16-20, 1/2-20, 9/16-18, 5/8-18, 3/4-16, *7/8-14, *1-14						
NPT (Regular Taper) 1/8-27, 1/4-18						
THREADING TOOLS IN SET						
Adjustable Tap Wrench - #4 to 1/2"			Die Stock - 1-7/8" Hex			
Adjustable Tap Wrench - 1/4 to 3/4"			T-Handle Tap Wrench - #0 - 1/4"			
Adjustable Tap Wrench - 1/2 to 1-1/8"			Screw Pitch Gauge - Fractional			
Die Stock - 1" Round or Hex			Screwdriver - 1/8" x 2-1/4" Pocket Clip			
Die Stock - 1-1/2" Round or 1-7/16" Hex						

Standard Packaging - 1 Ea. Box (Wt. 23.0 lbs.) • *7/8 & 1" NC & NF Hex Dies only available in High Carbon Steel.

117 PC TAP AND HEX DIE SET

PLASTIC CASES

117 Piece Titanium Nitride Coated Tap and Hexagon Die Sets are designed to be a professional tap and die set for mechanics and DIY'ers for maintenance on domestic cars, motorcycles, and machinery that were manufactured using the unified inch thread standard. Each set contains the most popular fractional size (1/4 to 1/2 NF/NC) and metric size (3mm to 12mm) taps and dies as well as five spiral screw extractors with corresponding tap drill sizes. The plastic case has individual compartments for all taps, dies, screw extractors and drills for easy access.

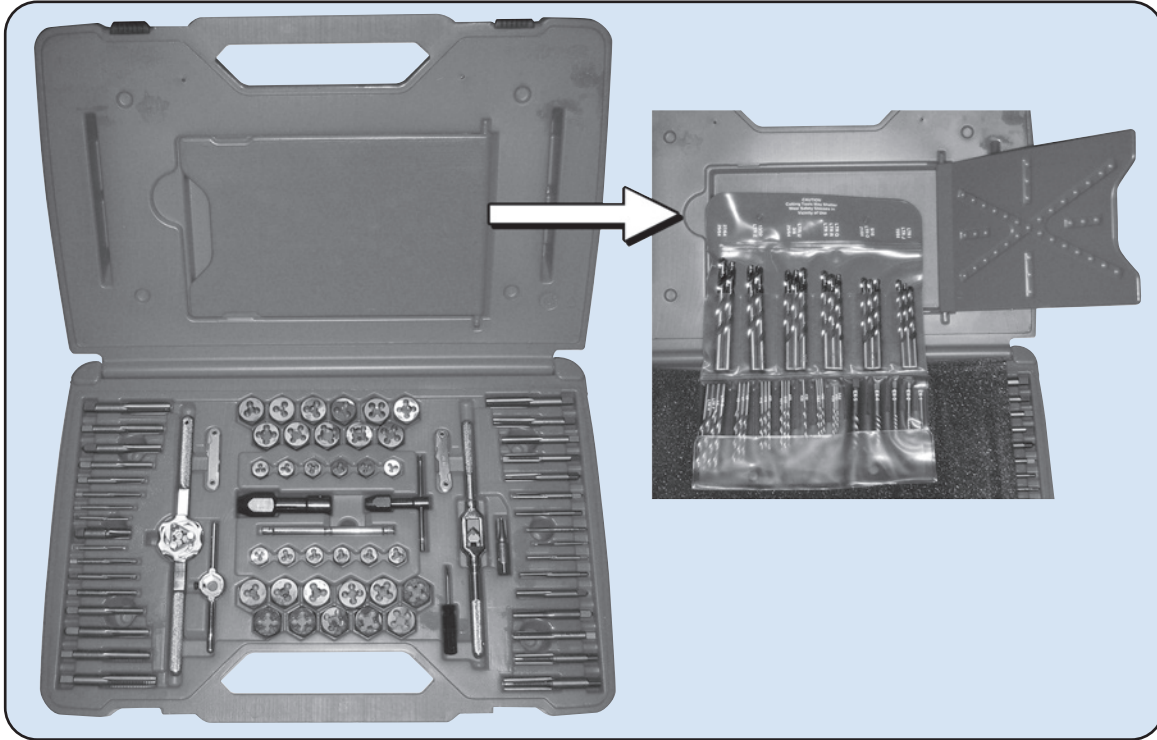

DESCRIPTION	CUT	THREAD TYPE	ITEM NO.	PRICE
Each set contains one each NC and NF fractional and metric plug taps and dies sizes. Sizes listed below. Set also includes 5 screw extractors and tap drills. All tools are titanium nitride coated.	Right Hand	NC, NF, NPT	THDS-CS-117	378.58
SIZES OF TAPS AND HEX DIES IN SET				
NC (Coarse)	1/4-20, 5/16-18, 3/8-16, 7/16-14, 1/2-13, M3.0x0.50, M4.0x0.75, M5.0x0.90, M7.0x1.0, M8.0x1.25, M9.0x1.25, M10.0x1.50, M12.0x1.75			
NF (Fine)	1/4-28, 5/16-24, 3/8-24, 7/16-20, 1/2-20, M4.0x0.70, M5.0x0.80, M6.0x1.00, M8.0x1.00, M9.0x1.00, M10.0x1.25, M11x1.50, M12.0x1.50			
NPT (Regular Taper)	1/8-27			
BSPT (British Standard)	1/8-28			
SIZES OF DRILLS IN SET				
Fractional Sizes	5/64, 7/64, 5/32, 1/4, 19/64, 5/16, 21/64, 3/8, 25/64, 13/32, 27/64, 29/64			
Wire Gauge Sizes	#3, #7, #9, #16, #19, #20, #21, #25, #29, #30, #36, #39, #43			
Letter Drill Sizes	B, F, H, I, J, O, Q, R, S, U, Z			
SIZES OF SCREW EXTRACTORS				
Screw Extractor Sizes	#1, #2, #3, #4, #5			
THREADING TOOLS IN SET				
Adjustable Tap Wrench - #4 to 1/2"	T-Handle Tap Wrench - #0 - 1/4"			
Die Stock - 5/8" Hex	T-Handle Tap Wrench - 1/4" - 1/2"			
Die Stock - 1" Hex	Screw Pitch Gauge - Fractional			
Screwdriver - 1/8"	Screw Pitch Gauge - Metric			

45 PC CARBON TAP AND ROUND ADJUSTABLE DIE SET

PLASTIC CASES

45 Piece Carbon Steel Fractional Tap and Die Sets were originally designed to be a basic general purpose tap and die set for mechanics and DIY'ers for maintenance on domestic cars, motorcycles, and machines that were manufactured using the unified inch thread standard. Each set contains the most popular sizes (1/4-20 to 1-14) that mechanics commonly use. Plastic case has individual compartments for tap and die storage and easy access.

ILLUSTRATION	DESCRIPTION	THREAD		ITEM NO.	PRICE	
		CUT	TYPE			
	Each set contains one each NC and NF Plug Tap and Round Adjustable Die. SIZES: 1/4" to 1"	Right Hand	NC, NF	TRDS-CS-45	581.70	
	SIZES OF TAPS AND ROUND ADJUSTABLE DIES IN SET					
	NC (Coarse)	#6-32, #8-32, #10-24, #12-24, 1/4-20, 5/16-18, 3/8-16, 7/16-14, 1/2-13, 9/16-12, 5/8-11, 3/4-10				
	NF (Fine)	#10-32, 1/4-28, 5/16-24, 3/8-24, 7/16-20, 1/2-20, 9/16-18, 5/8-18, 3/4-16				
	DIE DIMENSIONS AND DIE SIZES					
	1-1/2" Round Adjustable Dies		1/4" to 5/8"			
	2" Round Adjustable Dies		3/4" to 1"			
THREADING TOOLS IN SET						
Adjustable Tap Wrench - #4 to 1/2"		T-Handle Tap Wrench - #0 - 1/4"				
Adjustable Tap Wrench - 1/4 to 3/4"		Screw Pitch Gauge - Fractional				
Die Stock - 1" Round or Hex		Screwdriver - 1/8" x 2-1/4" Pocket Clip				

Standard Packaging - 1 Ea. Box (Wt. 23.0 lbs.)

45 PC METRIC CARBON TAP AND ROUND ADJUSTABLE DIE SET

PLASTIC CASES

45 Piece Carbon Steel Metric Tap and Die Sets were originally designed to be a basic general purpose tap and die set for mechanics and DIY'ers for maintenance on foreign cars, motorcycles, and machines that were manufactured using the unified inch thread standard. Each set contains the most popular metric sizes (M6 to M24) that mechanics commonly use. Plastic case has individual compartments for tap and die storage and easy access. With the advent of world trade, this set is now a staple in every tool box and workshop.

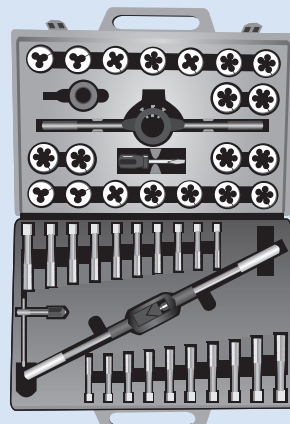
ILLUSTRATION	DESCRIPTION	THREAD		ITEM NO.	PRICE	
		CUT	TYPE			
	Each set contains one each NC and NF Plug Tap and Round Adjustable Die. SIZES: M6 to M24	Right Hand	NC, NF	TRDS-CS-45M	581.70	
	SIZES OF TAPS AND ROUND ADJUSTABLE DIES IN SET					
	NC (Coarse)	M6x1.00, M8x1.25, M10x1.50, M12x1.75, M14x2.00, M16x2.00, M18x2.50, M20x2.50, M22x2.50, 24x3.00				
	NF (Fine)	M6x0.75, M8x1.00, M10x1.25, M12x1.50, M14x1.50, M16x1.50, M18x1.50, M20x1.50, M22.0x1.50, M24x1.50				
	DIE DIMENSIONS AND DIE SIZES					
	1-1/2" Round Adjustable Dies		M6 to M18			
	2" Round Adjustable Dies		M20 to M24			
THREADING TOOLS IN SET						
Adjustable Tap Wrench - M6 to M18		T-Handle Tap Wrench - M6 to M12				
Die Stock Adapter - 1-1/2"		Screwdriver				
Die Stock - 2" Round						

Standard Packaging - 1 Ea. Box (Wt. 23.0 lbs.)

18 PC TAP AND DRILL SETS

METAL INDEXES

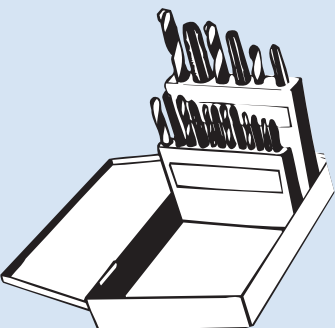
ILLUSTRATION	THREAD FORM	STYLE OF TAPS	CHAMFER	ITEM NO.	PRICE EACH	
	Coarse	HSS Spiral Point Tap	Plug	TDS-SPT-18C	100.72	
	Fine	HSS Spiral Point Tap	Plug	TDS-SPT-18F	102.62	
	Metric	HSS Spiral Point Tap	Plug	TDS-SPTM-18M	134.24	
	Coarse	TiN Coated Spiral Point Tap	Plug	TDS-SPTT-18C	202.36	
	Coarse	HSS Standard Hand Tap	Plug	TDS-SHT-18C	93.66	
	Fine	HSS Standard Hand Tap	Plug	TDS-SHT-18F	95.56	
	Metric	HSS Standard Hand Tap	Plug	TDS-SHTM-18M	110.90	
	Coarse	TiN Coated Std. Hand Tap	Plug	TDS-SHTT-18C	189.10	
	SIZES OF COARSE TAPS AND DRILLS IN 18 PC SETS					
	TAPS - #6-32, #8-32, #10-24, #10-32, 1/4-20, 5/16-18, 3/8-16, 7/16-14, 1/2-13 (COARSE) DRILLS - #36, #29, #25, #21, #7, "F", 5/16, "U", 27/64					
SIZES OF FINE TAPS AND DRILLS IN 18 PC SETS						
TAPS - #6-40, #8-36, #10-24, #10-32, 1/4-28, 5/16-24, 3/8-24, 7/16-20, 1/2-20 (FINE) DRILLS - #33, #29, #25, #21, #3, "I", "Q", 25/64, 29/64						
SIZES OF METRIC TAPS AND DRILLS IN 18 PC SETS						
TAPS - M2.5x.45, M3.0x.50, M3.5x.60, M4.0x.70, M5.0x.80, M6.0x1.00, M8.0x1.25, M10.0x1.50, M12.0x1.75 DRILLS - M2.05, M2.50, M2.90, M3.30, M4.20, M5.00, M6.70, M8.50, M10.20 (METRIC)						

TAP AND DRILL DISPENSER

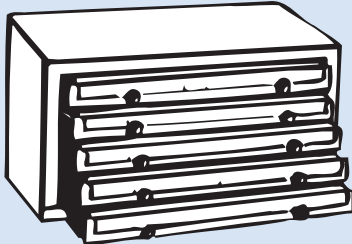
ILLUSTRATION	ITEM TYPE	ITEM NO.	EACH
	Dispenser Only (Wt. 10-1/2 lbs.)	D-TD-336	102.90
	DISPENSER WILL HOLD 12 EACH OF FOLLOWING		
	TAPS - #6-32, #8-32, #10-24, #10-32, 1/4-20, 1/4-28, 5/16-18, 5/16-24, 3/8-16, 3/8-24, 7/16-14, 7/16-20, 1/2-13, 1/2-20 DRILLS - #36, #29, #25, #21, #7, #3, "F", "I", 5/16, "Q", "U", 25/64, 27/64, 29/64		
Size: 7-3/8 x 7-3/4 x 14-5/8			

TAP DISPENSERS

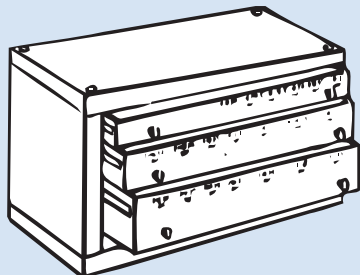
ILLUSTRATION	CAPACITY	ITEM NO.	EACH
	Holds fractional sizes 1/4-20 to 1-14 (Wt. 10-1/2 lbs.)	TD-FRACT	106.42
	Holds machine screw sizes 2-56 to 12-28 (Wt. 13 lbs.)	TD-MACH	131.62
	Holds metric sizes M3 to M24 (Wt. 10-1/2 lbs.)	TD-MM	106.42
	Note: Dispenser will hold up to 12 each of every size.		
Size: 7-3/8 x 7-3/4 x 14-5/8			

21 PC TAP AND ROUND ADJUSTABLE DIE SETS

WOODEN CASES

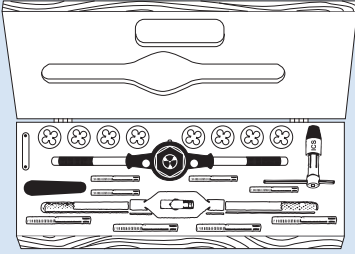
ILLUSTRATION	DESCRIPTION	STEEL SPEC	CUT	THREAD TYPE	ITEM NO.	PRICE
 <p>21 PC TAP AND ROUND ADJUSTABLE DIE SET</p>	21 PC Tap and 1-1/2" Round Adjustable Die Set. Each set contains one Plug Tap and Round Adjustable Die in NC or NF Thread Form. Sizes are listed below. Set also includes 5 threading tools.	HSS	Right Hand	Coarse	TRDS-SHT-21C	530.32
		HSS	Right Hand	Fine	TRDS-SHT-21F	530.32
		HSS	Left Hand	Coarse	TRDS-SHTL-21C	558.14
		HSS	Left Hand	Fine	TRDS-SHTL-21F	558.14
		TiN *	Right Hand	Coarse	TRDS-SHTT-21C	606.32
		TiN *	Right Hand	Fine	TRDS-SHTT-21F	606.32
SIZES OF TAPS AND ROUND DIES IN SET						
NC (Coarse) - 1/4-20, 5/16-18, 3/8-16, 7/16-14, 1/2-13, 9/16-12, 5/8-11, 3/4-10 NF (Fine) - 1/4-28, 5/16-24, 3/8-24, 7/16-20, 1/2-20, 9/16-18, 5/8-18, 3/4-16 * Only taps are TiN Coated in set.						
THREADING TOOLS IN SET						
Adjustable Die Stock - 1-1/2" round T-Handle Tap Wrench - 1/4 to 1/2 Adjustable Tap Wrench - 1/4 to 1 #5 Screwdriver Screw Pitch Gauge - Fractional						
Sizes: 1/4 to 3/4						

21 PC METRIC TAP AND ROUND ADJUSTABLE DIE SET

WOODEN CASES

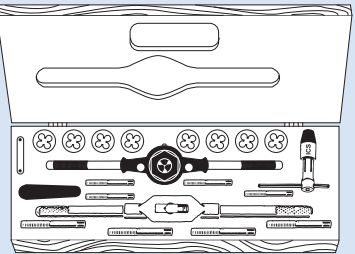
ILLUSTRATION	DESCRIPTION	STEEL SPEC	CUT	THREAD TYPE	ITEM NO.	PRICE	
 <p>21 PC TAP AND ROUND ADJUSTABLE DIE SET</p>	21 PC Tap and 1-1/2" Metric Round Adjustable Die Set. Each set contains one Plug Tap and Round Adjustable Die. Sizes are listed below. Set also includes 5 threading tools.	HSS	Right Hand	Metric Coarse	TRDS-SHTM-21C	582.10	
		SIZES OF TAPS AND ROUND DIES IN SET					
		NC (Coarse) - M6.0 x 1.0, M8.0 x 1.25, M10.0 x 1.5, M12.0 x 1.75, M14.0 x 2.0, M16.0 x 2.0, M18.0 x 2.5, M20.0 x 2.50					
		THREADING TOOLS IN SET					
		Adjustable Die Stock - 1-1/2" round T-Handle Tap Wrench - M6 to M12 Adjustable Tap Wrench - M6 to M24 #5 Screwdriver Screw Pitch Gauge - Metric					
		Sizes: M6 to M20					

NOTE: Special boxed sets can be made to your requirements.

54 PC AUTOMOTIVE RETHREADING TAP & DIE SET

PLASTIC CASES

ILLUSTRATION	DESCRIPTION	CUT	THREAD		ITEM NO.	PRICE
			TYPE			
 <p>54 PC AUTOMOTIVE RETHREADING TAP & DIE SET</p> <p>1/4 to 5/8 M6 to M14</p>	Each set contains one each NC & NF fractional & metric automotive rethreading taps and hex dies. Set also includes 3 thread restoring files.	Right Hand	NC & NF		ARTDS-54	123.90
	SIZES OF AUTOMOTIVE RETHREADING TAPS IN SET					
	NC-USS (Coarse) - 1/4-20, 5/16-18, 3/8-16, 7/16-14, 1/2-13, 9/16-12					
	NF-SAE (Fine) - 1/4-28, 5/16-24, 3/8-24, 7/16-20, 1/2-20, 9/16-18					
	METRIC - 6x1.0, 8x1.25, 8x1.50, 10x1.00, 10x1.25, 10x1.50, 11x1.50, 12x1.25, 12x1.50, 12x1.75, 14x1.50					
	SIZES OF AUTOMOTIVE RETHREADING DIES IN SET					
NC-USS (Coarse) - 1/4-20, 5/16-18, 3/8-16, 7/16-14, 1/2-13, 9/16-12, 5/8-11						
NF-SAE (Fine) - 1/4-28, 5/16-24, 3/8-24, 7/16-20, 1/3-20, 9/16-18, 5/8-18						
METRIC - 6x1.00, 6x1.25, 7x1.00, 8x1.00, 8x1.25, 8x1.50, 10x1.00, 10x1.25, 10x1.50, 11x1.50, 12x1.25, 12x1.50, 12x1.75, 14x1.50						
THREAD RESTORING FILES IN SET						
Regular File for - 11, 12, 13, 14, 16, 18, 20, 24 threads per inch						
Metric File for - .80, 1.00, 1.25, 1.50, 1.75, 2.00, 2.50, 3.00 threads per inch						
Fine/Pipe File for - 8, 9, 10, 11-1/2, 20, 27, 28, 32 threads per inch						

18 PC THREAD RESTORING FILE & AUTOMOTIVE DIE SETS

PLASTIC CASES

ILLUSTRATION	DESCRIPTION	CUT	THREAD		ITEM NO.	PRICE
			TYPE			
 <p>18 PC AUTOMOTIVE FILE & AUTOMOTIVE DIE SET</p>	Each set contains one each NC & NF fractional automotive hexagon rethreading dies. Set also includes 2 thread restoring files.	Right Hand Left Hand	NC & NF NC & NF		TRFADS-18 TRFADS-18L	50.40 80.14
	SIZES OF AUTOMOTIVE RETHREADING DIES IN SET					
	NC-USS (Coarse) - 1/4-20, 5/16-18, 3/8-16, 7/16-14, 1/2-13, 9/16-12, 5/8-11, 3/4-10					
	NF-SAE (Fine) - 1/4-28, 5/16-24, 3/8-24, 7/16-20, 1/3-20, 9/16-18, 5/8-18, 3/4-16					
	THREAD RESTORING FILES IN SET					
	Regular File for - 11, 12, 13, 14, 16, 18, 20, 24 threads per inch					
Extra Fine/Coarse File for - 9, 10, 12, 16, 20, 27, 28, 32 threads per inch						
AVAILABLE IN RIGHT OR LEFT HAND THREAD						

13 PC METRIC THREAD RESTORING FILE & AUTOMOTIVE DIE SET

PLASTIC CASES

ILLUSTRATION	DESCRIPTION	CUT	THREAD		ITEM NO.	PRICE
			TYPE			
 <p>13 PC AUTOMOTIVE FILE & AUTOMOTIVE DIE SET</p>	Each set contains one each metric automotive hexagon rethreading dies and one each thread restoring file.	Right Hand	Metric		TRFADS-13M	37.28
	SIZES OF AUTOMOTIVE RETHREADING DIES IN SET					
	METRIC - 6x1.0, 6x1.25, 8x1.00, 8x1.25, 8x1.50, 10x1.00, 10x1.25, 10x1.50, 12x1.25, 12x1.50, 14x1.25, 14x1.50					
	THREAD RESTORING FILES IN SET					
Metric File for - .80, 1.00, 1.25, 1.50, 1.75, 2.00, 2.50, 3.00 threads per inch						

HIGH SPEED STEEL 30 PC MINIATURE TAP AND ROUND DIE SET

PLASTIC CASE

30 piece High Speed Steel Machine Screw Size Miniature Tap and Die Sets are designed to be a professional general purpose tap and die set with all the most popular tap and die machine screw sizes (#0 to #4-40) for use by camera repair shops, clock repair shops, model builders, jewelry manufacturers, business machine repair, electronic equipment, mold and die makers, medical equipment repair, fishing lure manufacturers, and tongue and body piercing. Plastic case has individual compartments for tap and die storage and easy access.

ILLUSTRATION	DESCRIPTION	STEEL SPEC	THREAD CUT	THREAD TYPE	ITEM NO.	PRICE
	Each set contains 2 plug taps and 1 round die for every size. Set also includes multi-size tap and die holder.	HSS	Right Hand	NC, NF UM	MTRDS-30	40.96
	SIZES OF TAPS AND ROUND DIES IN SET					
	NC (Coarse)	#0-80, #1-64, #2-56, #3-48, #4-40				
	NF (Fine)	#0-90, #1-72, #2-64, #3-56				
TAP AND ROUND DIE HOLDER IN SET						
Multi-Size Tap and Die Holder holds 5/8 or 7/16 round dies and has two collet guides for holding taps. Both taps and dies lock into position with one screw.						

HIGH SPEED STEEL 30 PC METRIC MINIATURE TAP AND ROUND DIE SET

PLASTIC CASE

30 piece High Speed Steel Metric Size Miniature Tap and Die Sets are designed to be a professional general purpose tap and die set with all the most popular tap and die metric sizes (M1.00 to M2.50) for use by camera repair shops, clock repair shops, model builders, jewelry manufacturers, business machine repair, electronic equipment, mold and die makers, medical equipment repair, fishing lure manufacturers, and tongue and body piercing. Plastic case has individual compartments for tap and die storage and easy access.

ILLUSTRATION	DESCRIPTION	STEEL SPEC	THREAD CUT	THREAD TYPE	ITEM NO.	PRICE
	Each set contains 2 plug taps and 1 round die for every size. Set also includes multi-size tap and die holder.	HSS	Right Hand	NC, NF UM	MTRDS-30M	40.96
	SIZES OF TAPS AND ROUND DIES IN SET					
	METRIC SIZES	M1.0x0.25, M1.1x0.25, M1.2x0.25, M1.4x0.30, M1.6x0.35 M1.8x0.35, M2.0x0.40, M2.2x0.45, M2.5x0.45				
	TAP AND ROUND DIE HOLDER IN SET					
Multi-Size Tap and Die Holder holds 5/8 or 7/16 round dies and has two collet guides for holding taps. Both taps and dies lock into position with one screw.						

5 PC MODEL AIRPLANE TAP SETS

PLASTIC CASE

Model Airplane Tap Sets were designed for the model airplane enthusiast. Available in High Speed Steel or Carbon Steel, each set contains the most popular tap sizes (#2-56 to #8-32) that model airplane builders use. Plastic case has individual compartments for tap storage and easy access.

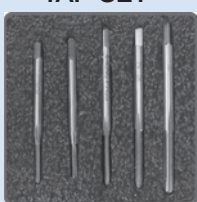
ILLUSTRATION	DESCRIPTION	STEEL SPEC	THREAD TYPE	ITEM NO.	PRICE
	Each set contains one each of listed NC (Coarse) tap sizes.	Carbon Steel High Speed Steel	NC NC	MATS-CS-5 MATS-HS-5	22.06 30.46
	SIZES OF TAPS IN SET				
	NC (Coarse)	#2-56, #3-48, #4-40, #6-32, #8-32			

8 PC RATCHETING PIPE THREADER SET

PLASTIC CASE

The 8 Piece Ratcheting Pipe Threader Set was designed to cut precision NPT pipe threads measuring 3/8", 1/2", 3/4", 1", or 1-1/4". It is a compact and sturdy set complete with unscrewable ratchet handle and extension. Die heads snap in and can be removed by pulling the ratchet knob out to position. Ratchet knob can be set for forward or reverse direction. Tools in set are made of alloy steel and malleable iron to withstand severe usage. Set comes complete with heavy duty plastic case with carrying handle for easy transportation and storage.

ILLUSTRATION	THREADING TOOLS IN SET	THREAD FORM	ITEM NO.	PRICE
<p data-bbox="175 411 444 468">8 PC RATCHETING PIPE THREADER SET</p> 	<p data-bbox="574 411 985 548">Die Heads 3/8, 1/2, 3/4, 1, & 1-1/4 Ratchet Head (Exposed Style) Ratchet Handle Ratchet Handle Extension</p>	<p data-bbox="1127 411 1182 436">NPT</p>	<p data-bbox="1304 411 1398 436">RPTS-8</p>	<p data-bbox="1455 411 1528 436">96.92</p>

7 PC RATCHETING PIPE THREADER SET

PLASTIC CASE

The 7 Piece Ratcheting Pipe Threader Set was designed to cut large precision NPT pipe threads measuring 1-1/4", 1-1/2" and 2". It is a compact and sturdy set complete with unscrewable ratchet handle and extension. Die heads snap in and can be removed by pulling the ratchet knob out to position. Ratchet knob can be set for forward or reverse direction. Tools in set are made of alloy steel and malleable iron to withstand severe usage. Set comes complete with heavy duty plastic case with carrying handle for easy transportation and storage.

ILLUSTRATION	THREADING TOOLS IN SET	THREAD FORM	ITEM NO.	PRICE
<p data-bbox="175 1390 444 1446">7 PC RATCHETING PIPE THREADER SET</p> 	<p data-bbox="574 1390 935 1526">Die Heads 1-1/4, 1-1/2, & 2 Ratchet Head (Exposed Style) Ratchet Handle Ratchet Handle Extensions (2)</p>	<p data-bbox="1127 1390 1182 1415">NPT</p>	<p data-bbox="1304 1390 1398 1415">RPTS-7</p>	<p data-bbox="1455 1390 1528 1415">101.80</p>

5 PC RATCHETING TAP AND DIE TOOL SET

STEEL CASE

The 5 Piece Ratcheting Tap and Die Tool Sets are designed to be a professional general purpose tap and die tool set for mechanics and DIYers for maintenance on domestic cars and motorcycles. Each set contains the most popular tap sockets (#6 to 1/2") and 1" hex die adapter with ratcheting handle. Steel case has individual compartments for ratcheting tap and die tools storage and easy access.

ILLUSTRATION	RATCHETING TOOLS IN SET	ITEM NO.	PRICE
<p>5 PC RATCHETING TAP AND DIE TOOL SET</p> 	Adjustable Tap Socket #6 - 1/4 Adjustable Tap Socket 1/4 - 1/2 1" Hex Die Socket Adapter Ratcheting Handle Sliding Handle for Tap Sockets	RTDTS-5	52.48

THREAD BOX AND TAP SETS

ICS USA

SPECIAL PURPOSE

Thread Box and Tap Sets are designed to make sure-holding threads on wood dowels and matching thread hole in wood. Handy set for woodworking and maintenance departments. Each wood threading set contains thread box and matching tap. Handy for threading, rethreading or tapping many wood furnishings. Perfect for the DIYer.

Thread Box - Top View

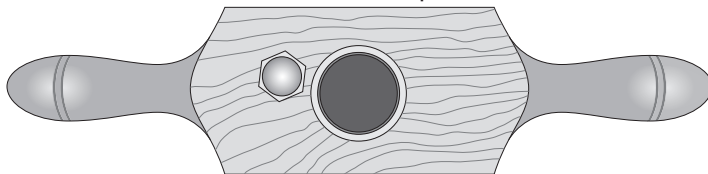

Thread Box - 3/4 Profile View

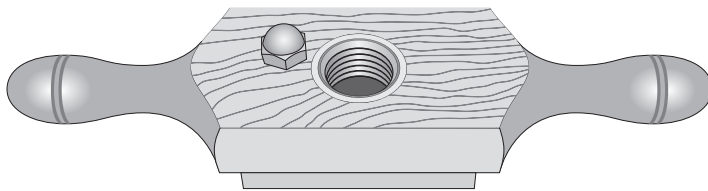

Tap

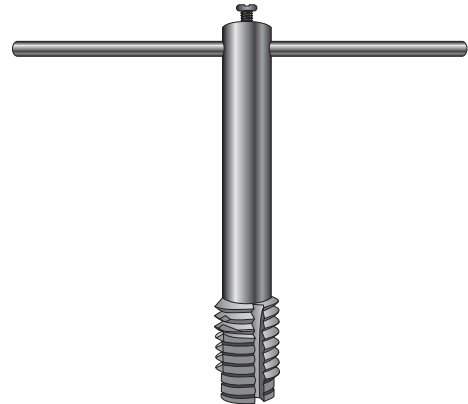

FOR USE WITH	SET CONTAINS	ITEM NO.	PRICE
1/2" Dowel Rod	1 each: tap and thread box	WTS032	48.30
3/4" Dowel Rod	1 each: tap and thread box	WTS048	51.82
1" Dowel Rod	1 each: tap and thread box	WTS100	55.24

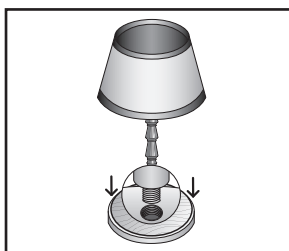

1. Threading and/or tapping wooden lamps.

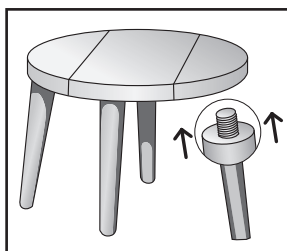

2. Threading and/or tapping stools and chairs.

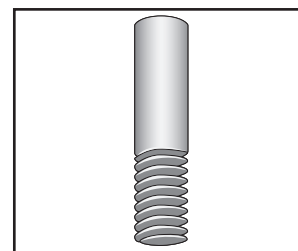

3. Threading or rethreading broomstick/mop handles.

CARBIDE (GRADE C-6) CARBIDE TIPPED BORING BAR SETS

WOOD STAND

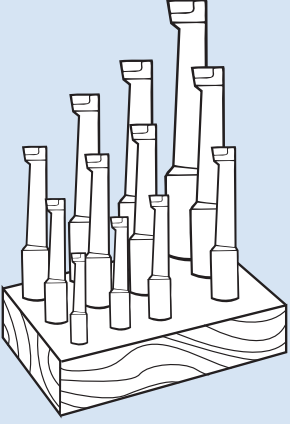

ILLUSTRATION	DESCRIPTION	ITEM NO.	PRICE
	9 PC SET - 3/8" SHANK Carbide Tipped Boring Bars	CTBBS-A-9	45.08
	9 PC SET - 1/2" SHANK Carbide Tipped Boring Bars	CTBBS-B-9	59.32
	12 PC SET - 5/8" SHANK Carbide Tipped Boring Bars	CTBBS-C-12	104.46
	12 PC SET - 3/4" SHANK Carbide Tipped Boring Bars	CTBBS-D-12	137.94
	7 PC SET - 1" SHANK Carbide Tipped Boring Bars	CTBBS-E-7	183.96

MINI TOOLHOLDER & BORING BAR SET

ICS **EUR**

SPECIAL PURPOSE

PRECISION GROUND

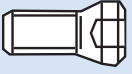
ILLUSTRATION	DESCRIPTION	ITEM NO.	PRICE	
<p>5 PC MINI TOOLHOLDER AND BORING BAR SET</p> 	5 PC Mini Toolholder & Boring Bar Set in plastic case. Each set contains one each of four types of Toolholders and one Boring Bar. Set also includes 1 Torx Key and 2 spare Locking Screws. Inserts are sold separately.	IMT-MTBBS-5	264.60	
	MINI TOOLHOLDERS AND BORING BAR IN SET			
	ITEM NO.	DESCRIPTION	CUT	INSERT USED
	IMT-SCLCR04-2	Mini Toolholders	Right Hand	I-CCMT21.51
	IMT-SDJCR04-2		Right Hand	I-DCMT21.51
IMT-SDJCL04-2	Left Hand		I-DCMT21.51	
IMT-SSDCN04-2	Neutral		I-SCMT21.51	
IT-SCLCR04-2	Boring Bar	Right Hand	I-CCMT21.51	
SPARE PARTS IN SET				
				
TORX KEY		LOCKING SCREW		
ITEM NO.	PRICE	ITEM NO.	PRICE	
ISP-TK-T07	6.30	ISP-LS-3	1.06	

(M3) BI-METAL HOLE SAW KITS

PLASTIC CASES

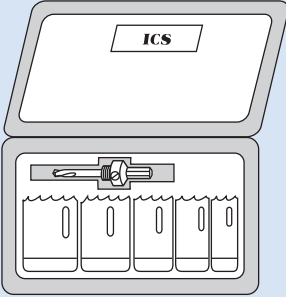
ILLUSTRATION	DESCRIPTION	ITEM NO.	PRICE	
	MECHANIC'S HOLE SAW KIT - 1 ea. 7/8, 1, 1-1/8, 1-1/4, 1-1/2 Hole Saws, HSM-6 Arbor.	HSK-BM-06M	81.78	
	MAINTENANCE HOLE SAW KIT - 1 ea. 3/4, 7/8, 1-1/8, 1-3/8, 1-1/2, 1-3/4, 2, 2-1/4, 2-1/2 Hole Saws, HSM-3, HSM-4, HSM-6 Arbors and 12" extension.	HSK-BM-13M	216.86	
	PLUMBER'S HOLE SAW KIT - 1 ea. 3/4, 7/8, 1-1/8, 1-1/2, 1-3/4, 2-1/4 Hole Saws, HSM-3 and HSM-4 Arbors, and HSPD-3S Pilot Drill.	HSK-BM-09P	146.24	
	ELECTRICIAN'S HOLE SAW KIT - 1 ea. 7/8, 1-1/8, 1-3/8, 1-3/4, 2, 2-1/2 Hole Saws, HSM-3 and HSM-4 Arbors, and HSPD-3S Pilot Drill.	HSK-BM-09E	159.52	
	METRIC			
	MECHANIC'S METRIC HOLE SAW KIT - 1 ea. 22mm, 25mm, 29mm, 32mm, 38mm Hole Saws, HSM-6 Arbor.	HSK-BMM-06M	81.78	
	MAINTENANCE METRIC HOLE SAW KIT - 1 ea. 19mm, 22mm, 29mm, 35mm, 38mm, 44mm, 51mm, 57mm, 64mm Hole Saws, HSM-3, HSM-4, HSM-6 Arbors and 12" extension.	HSK-BMM-13M	216.86	
	PLUMBER'S METRIC HOLE SAW KIT - 1 ea. 19mm, 22mm, 29mm, 38mm, 44mm, 57mm Hole Saws, HSM-3 and HSM-4 Arbors, and HSPD-3S Pilot Drill.	HSK-BMM-09P	146.24	
	ELECTRICIAN'S METRIC HOLE SAW KIT - 1 ea. 22mm, 29mm, 35mm, 44mm, 51mm, 64mm Hole Saws, HSM-3 and HSM-4 Arbors, and HSPD-3S Pilot Drill.	HSK-BMM-09E	159.52	

(M3) BI-METAL HOLE SAW KITS (BUILT-IN ARBOR)

PLASTIC CASES

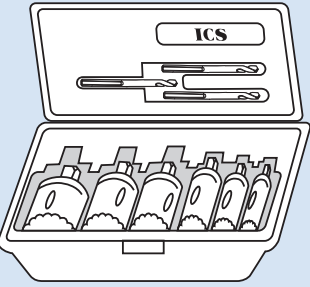
ILLUSTRATION	DESCRIPTION	ITEM NO.	PRICE	
	MECHANIC'S HOLE SAW KIT - 1 ea. 7/8, 1, 1-1/8, 1-1/4, 1-1/2 Hole Saws, and 1 Pilot Drill	HSK-BMA-06	87.02	
	ELECTRICIAN'S HOLE SAW KIT - 1 ea. 7/8, 1-1/8, 1-3/8, 1-3/4, 2, 2-1/2 Hole Saws, and 3 Pilot Drills	HSK-BMA-09E	122.80	
	PLUMBER'S HOLE SAW KIT - 1 ea. 3/4, 7/8, 1-1/8, 1-1/2, 1-3/4, 2-1/4 Hole Saws, and 3 Pilot Drills	HSK-BMA-09P	116.50	
	MAINTENANCE HOLE SAW KIT - 1 ea. 3/4, 7/8, 1-1/8, 1-3/8, 1-1/2, 1-3/4, 2, 2-1/4, 2-1/2 Hole Saws, 4 Pilot Drills, 12" Extension, and 1 Screwdriver	HSK-BMA-15M	201.78	
	METRIC			
	MECHANIC'S METRIC HOLE SAW KIT - 1 ea. 22mm, 25mm, 29mm, 32mm, 38mm Hole Saws	HSK-BMMA-06	87.02	
	MAINTENANCE METRIC HOLE SAW KIT - 1 ea. 19mm, 22mm, 29mm, 35mm, 38mm, 44mm, 51mm, 57mm, 64mm Hole Saws, 12" Extension and HSPD-3S Pilot Drills.	HSK-BMMA-15M	216.86	
	PLUMBER'S METRIC HOLE SAW KIT - 1 ea. 19mm, 22mm, 29mm, 38mm, 44mm, 57mm Hole Saws, and HSPD-3S Pilot Drill.	HSK-BMMA-09P	146.24	
	ELECTRICIAN'S METRIC HOLE SAW KIT - 1 ea. 22mm, 29mm, 35mm, 44mm, 51mm, 64mm Hole Saws, and HSPD-3S Pilot Drill.	HSK-BMMA-09E	159.52	

**CARBIDE TIPPED
HOLE SAW KIT**

PLASTIC CASES

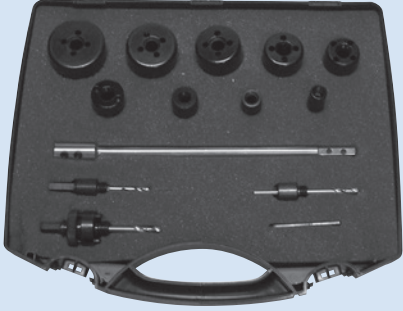
ILLUSTRATION	DESCRIPTION	ITEM NO.	PRICE
	<p>MAINTENANCE CARBIDE TIPPED HOLE SAW KIT 1 ea. 3/4, 7/8, 1-1/8, 1-3/8, 1-1/2, 1-3/4, 2-1/4, 2-1/2 Hole Saws. HSM-3, HSM-4, HSM-6 Arbors and 12" extension.</p>	<p>HSK-CT-13M</p>	<p>294.00</p>

**CARBIDE GRIT EDGED
HOLE SAW KITS**

PLASTIC CASES

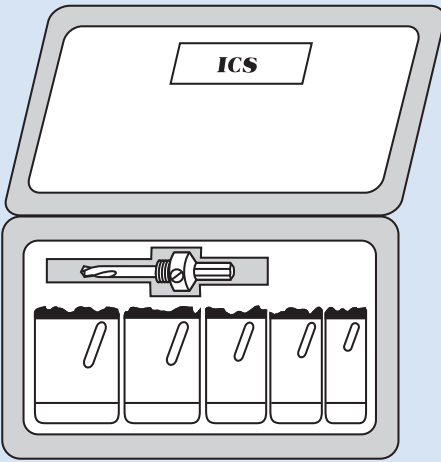
ILLUSTRATION	DESCRIPTION	ITEM NO.	PRICE
	<p>MECHANIC'S CARBIDE GRIT EDGED HOLE SAW KIT 1ea. 7/8, 1, 1-1/8, 1-1/4, 1-1/2 Hole Saws, HSM-6 Arbor.</p>	<p>HSK-CE-06M</p>	<p>224.88</p>
	<p>MAINTENANCE CARBIDE GRIT EDGED HOLE SAW KIT 1 ea. 3/4, 7/8, 1-1/8, 1-3/8, 1-1/2, 1-3/4, 2, 2-1/4, 2-1/2 Hole Saws, HSM-3, HSM-4, HSM-6 Arbors and 12" Extension</p>	<p>HSK-CE-13M</p>	<p>511.84</p>
	<p>PLUMBER'S CARBIDE GRIT EDGED HOLE SAW KIT 1 ea. 3/4, 7/8, 1-1/8, 1-1/2, 1-3/4, 2-1/4 Hole Saws, HSM-3 and HSM-4 Arbors, and HSPD-3S Pilot Drill.</p>	<p>HSK-CE-09P</p>	<p>331.34</p>
	<p>ELECTRICIAN'S CARBIDE GRIT EDGED HOLE SAW KIT 1 ea. 7/8, 1-1/8, 1-3/8, 1-3/4, 2, 2-1/2 Hole Saws, HSM-3 and HSM-4 Arbors, and HSPD-3S Pilot Drill.</p>	<p>HSK-CE-09E</p>	<p>357.68</p>

**CARBIDE TIPPED
HOLE CUTTER KIT**

DESCRIPTION	ITEM NO.	PRICE
<p>Electrician's Carbide Tipped Hole Cutter Set 1 each: 7/8", 1-1/8", 1-3/8", 1-3/4", 2", 2-1/2" Packaged in a plastic case.</p>	<p>HCS-CT-06E</p>	<p>369.60</p>

FILE SETS (AMERICAN PATTERN)

VINYL POUCHES

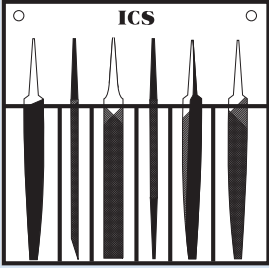
DESCRIPTION	LENGTH INCH	CUT	ITEM NO.	PRICE PER SET
6 PC FILE SET 	4	Bastard	FS-AP-4	25.46
	6		FS-AP-6	27.40
	8		FS-AP-8	37.32
TYPE OF FILES IN 6 PC SET				
	1 - Three Square	1 - Flat Taper		
	1 - Square	1 - Round		
	1 - Flat Hand	1 - Half Round		

NEEDLE FILE SETS

VINYL POUCHES

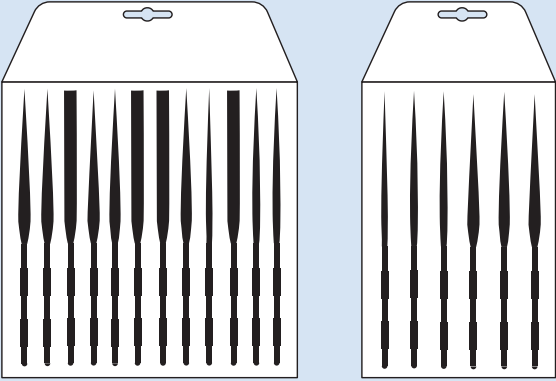
DESCRIPTION	LENGTH INCH	ITEM NO.			PRICE EACH
		CUT #0	CUT #2	CUT #3	
NEEDLE FILE SETS 12 PC 6 PC 	12 PC SETS - 1 EACH ALL SHAPES				
	4	NFS-12-40	NFS-12-42	NFS-12-43	26.84
	5-1/2	NFS-12-50	NFS-12-52	NFS-12-53	35.74
	6	NFS-12-60	NFS-12-62	NFS-12-63	35.74
	6 PC SETS				
	4	-	NFS-6-42	-	15.28
	5-1/2	-	NFS-6-52	-	19.76
	6	-	NFS-6-62	-	19.76
	CONTENTS OF 6 PC SET				
	1 ea. Round, Square, Three Square, Equalling (Hand), Half Round and Flat (Warding).				

DIAMOND COATED NEEDLE FILE SET

VINYL POUCH

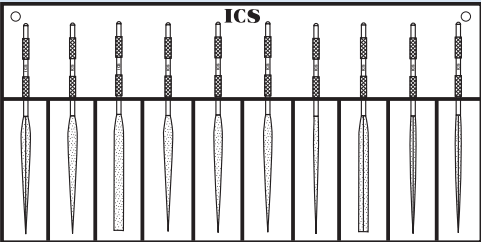
DESCRIPTION	OVERALL LENGTH	LENGTH OF CUT	GRIT	ITEM NO.	PRICE PER SET
10 PC NEEDLE FILE SET (Diamond Coated) 	4	1-1/2	12	DCNFS-SP-10	25.88
CONTENTS OF SET					
	1 - Round	1 - Crossing			
	1 - Half Round	1 - Equaling			
	1 - Square	1 - Barrette			
	1 - Three Square	1 - Marking			
	1 - Flat	1 - Slitting			

PRECISION (SWISS PATTERN) FILE SET

VINYL POUCH

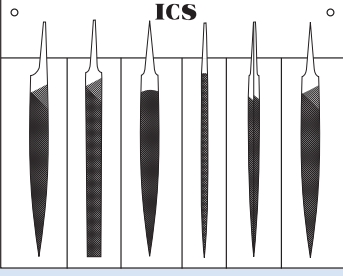
DESCRIPTION	LENGTH	CUT #0		CUT #2	
	INCH	ITEM NO.	PRICE	ITEM NO.	PRICE
6 PC PRECISION FILE SET 	6	PFS-SP-06#0	140.00	PFS-SP-06#2	163.14
	TPYE OF FILES IN SETS 1 - Half Round 1 - Round 1 - Knife 1 - Three Square 1 - Pillar (Reg.) 1 - Warding				

RIFFLER (SWISS PATTERN) RASP SET

VINYL POUCH

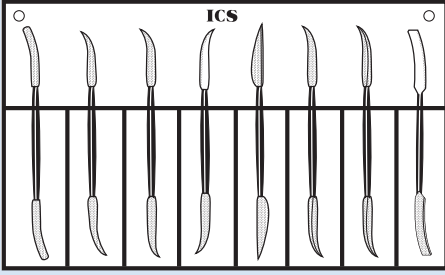
DESCRIPTION	LENGTH	CUT	ITEM NO.	PRICE
	INCH			PER SET
8 PC RIFFLER RASP SET 	7-1/2	Rasp	RRS-SP-8	34.36
CONTENTS OF SET One each of eight different shaped Riffler Rasps for woodworking, carving, and sculpting.				

EXTERNAL THREAD RESTORING FILE SETS

VINYL POUCHES

DESCRIPTION	FILES IN SET	ITEM NO.	PRICE
6PC EXTERNAL THREAD RESTORING FILE SET 	ETRF-R ETRF-X ETRF-M ETRF-P4 ETRF-P4L UTRF	ETRFS-6	68.26
4PC EXTERNAL THREAD RESTORING FILE SET 3 each EXTERNAL THREAD FILES 1 UNIVERSAL THREAD FILE (NOT ILLUSTRATED)	ETRF-R ETRF-M ETRF-P4 UTRF	ETRFS-4U	35.70
3PC EXTERNAL THREAD RESTORING FILE SET 3 each EXTERNAL THREAD FILES (NOT ILLUSTRATED)	ETRF-R ETRF-X ETRF-M	ETRFS-3	34.66

SOLID CARBIDE BUR SETS

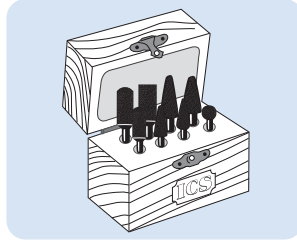
ICS USA
WOODEN BOXES
CNC GROUND

DESCRIPTION	SIZE / TYPE OF BUR	SHANK	CUT	ITEM NO.	PRICE
8 PC BUR SETS	Reg. Sizes-Solid Carbide	1/4	Double	SCBSW-SCB-8	312.22
	Reg. Sizes-Solid Carbide-TiN Coated	1/4	Double	SCBSW-SCBT-8	CALL
	SIZES OF BURS IN SETS				
1/4" SHANK	SA-5, SC-3, SC-5, SD-5, SF-3, SF-5, SG-3, SL-4				
8 PC NF BUR SETS	Reg. Sizes-NF Solid Carbide	1/4	NF	SCBSW-NF-8	385.64
	Reg. Sizes-NF Solid Carbide-ZrN Coated	1/4	NF	SCBSW-NFZ-8	430.22
	SIZES OF BURS IN SETS				
1/4" SHANK	SA-5, SC-3, SC-5, SD-5, SF-3, SF-5, SE-5, SL-4				
16 PC BUR SETS	Reg. Sizes-Solid Carbide	1/4	Double	SCBSW-SCB-16	449.54
	Reg. Sizes-Solid Carbide-TiN Coated	1/4	Double	SCBSW-SCBT-16	490.62
	SIZES OF BURS IN SETS				
1/4" SHANK	SA-1, SA-3, SA-5, SC-1, SC-3, SC-5, SD-3, SD-5, SE-3, SF-1, SF-3, SF-5, SG-1, SG-3, SL-3, SL-4				
8 PC BUR SETS	#81 Sizes-Solid Carbide	3/16	Double	SCBSW #81-8	139.06
	#81 Sizes-Solid Carbide-TiN Coated	3/16	Double	SCBSW #81T-8	167.66
	SIZES OF BURS IN SETS				
3/16" SHANK	SA #81, SC #81, SD #81, SE #81, SF #81, SG #81, SL #81, SN #81				
9 PC BUR SETS	#51 Sizes-Solid Carbide	1/8	Double	SCBSW #51-9	142.60
	#51 Sizes-Solid Carbide-TiN Coated	1/8	Double	SCBSW #51T-9	169.68
	SIZES OF BURS IN SETS				
1/8" SHANK	SA #51, SB #51, SC #51, SD #51, SE #51, SF #51, SG #51, SM #51, SN #51				
12 PC BUR SETS	#52/#53 Sizes-Solid Carbide	1/8	Double	SCBSW #52-12	260.02
	#52/#53 Sizes-Solid Carbide-TiN Coated	1/8	Double	SCBSW #52T-12	296.14
	SIZES OF BURS IN SETS				
1/8" SHANK	SA #52, SA #53, SC #52, SC #53, SD #53, SE #53, SF #53, SG #53, SH #53, SL #53, SM #53, SN #53				
12 PC BUR SETS	#41-#43 Sizes-Solid Carbide	1/8	Double	SCBSW #41-12	119.64
	#41-#43 Sizes-Solid Carbide-TiN Coated	1/8	Double	SCBSW #41T-12	147.86
	SIZES OF BURS IN SETS				
1/8" SHANK	SA #52, SA #53, SC #52, SC #53, SD #53, SE #53, SF #53, SG #53, SH #53, SL #53, SM #53, SN #53				
9 PC BUR SETS	#61-#63 Sizes-Solid Carbide	3/32	Double	SCBSW #61-9	105.52
	#61-#63 Sizes-Solid Carbide-TiN Coated	3/32	Double	SCBSW #61T-9	126.70
	SIZES OF BURS IN SETS				
3/32" SHANK	SA #61, SA #63, SC #61, SD #61, SE #61, SF #61, SG #61, SM #61, SN #61				

SOLID CARBIDE BUR SETS

ICS USA

METAL INDEXES

CNC GROUND

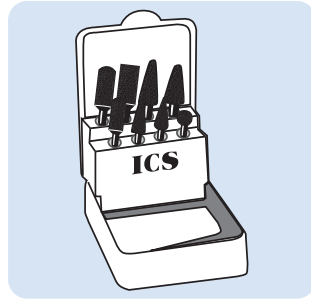

DESCRIPTION	SIZE / TYPE OF BUR	SHANK	CUT	ITEM NO.	PRICE
8 PC BUR SETS	Reg. Sizes-Solid Carbide	1/4	Double	SCBS-SCB-8	235.38
	Reg. Sizes-Solid Carbide-TiN Coated	1/4	Double	SCBS-SCBT-8	442.24
SIZES OF BURS IN SETS					
1/4" SHANK	SA-5, SC-3, SC-5, SD-5, SF-3, SF-5, SG-3, SL-4				
8 PC NF BUR SETS	Reg. Sizes-NF Solid Carbide	1/4	Double	SCBS-SCBNF-8	370.72
	Reg. Sizes-NF Solid Carbide-TiN Coated	1/4	Double	SCBS-SCBNFZ-8	418.14
SIZES OF BURS IN SETS					
1/4" SHANK	SA-5, SC-3, SC-5, SD-5, SE-5, SF-3, SF-5, SL-4				
11 PC BUR SETS	Reg. Sizes-Solid Carbide	1/4	Double	SCBS-SCB-11	300.60
	Reg. Sizes-Solid Carbide-TiN Coated	1/4	Double	SCBS-SCBT-11	345.82
SIZES OF BURS IN SETS					
1/4" SHANK	SA-3, SA-5, SC-3, SC-5, SD-3, SD-5, SE-3, SF-3, SF-5, SL-3, SL-4				
9 PC BUR SETS	#51 Sizes-Solid Carbide	1/8	Double	SCBS #51-9	138.26
	#51 Sizes-Solid Carbide-TiN Coated	1/8	Double	SCBS #51T-9	165.36
SIZES OF BURS IN SETS					
1/8" SHANK	SA #51, SB #51, SC #51, SD #51, SE #51, SF #51, SG #51, SM #51, SN #51				
13 PC BUR SETS	#52-#53 Sizes-Solid Carbide	1/8	Double	SCBS #52-13	275.88
	#52-#53 Sizes-Solid Carbide-TiN Coated	1/8	Double	SCBS #52T-13	315.02
SIZES OF BURS IN SETS					
1/8" SHANK	SA #52, SA #53, SC #52, SC #53, SD #52, SD #53, SE #53, SF #53, SG #53, SH #53, SL #53, SM #53, SN #53				
13 PC BUR SETS	#41-#43 Sizes-Solid Carbide	1/8	Double	SCBS #41-13	123.62
	#41-#43 Sizes-Solid Carbide-TiN Coated	1/8	Double	SCBS #41T-13	154.18
SIZES OF BURS IN SETS					
1/8" SHANK	SA #42, SA #43, SC #41, SC #42, SD #42, SE #41, SF #42, SG #43, SH #41, SJ #42, SL #53, SM #53, SN #53				

ICS CUTTING TOOLS, INC
511 MAIN STREET • CASCO, WI 54205-0125 USA



SCAN FOR LATEST ONLINE CATALOGS



SCAN TO OPEN THE WEBSITE

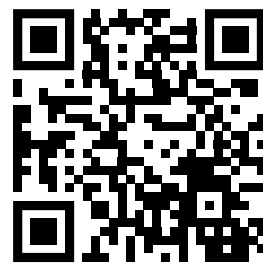

(920) 837-2526 • FAX (920) 837-2530
www.icscuttingtools.com • info@icscuttingtools.com