

**CARBIDE TIPPED
HOLE CUTTER - DOUBLE BLADED**

ICS WIS

HEAVY DUTY

3 FLAT
1/2" SHANK

4 CARBIDE
TIPPED BLADES

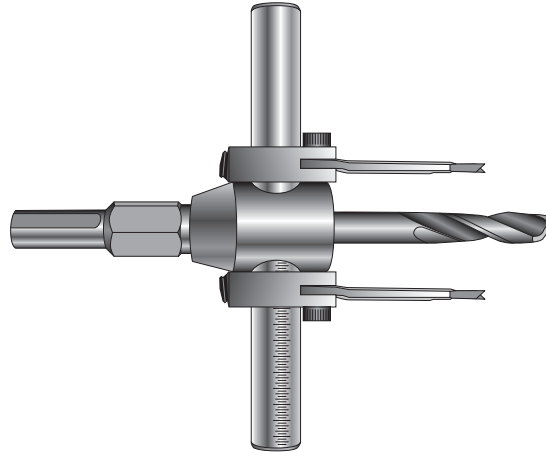

The Carbide Tipped Double Bladed Hole Cutter is designed for cutting 1-3/16" to 5-1/2" holes in sheet metal, copper, brass, aluminum, plastic, wood and composition. Maximum 1-3/4" cutting depth. Supplied with hex wrench and pilot hole drill. Measurement scale is etched on cross beam to easily set hole size. Use in any drill press or drill stand. Do not use in hand held power tools.

FOR CUTTING	CUTTING DEPTH	SHANK	ITEM NO.	PRICE
1-3/16" to 5-1/2" Holes	1-3/4	1/2	CTAHC532	30.30

**HIGH SPEED STEEL
HOLE CUTTER - CIRCLE**

ICS WIS

TREPPANNING TOOL

#2 OR #3
MORSE TAPER SHANK

3 CAPACITY LENGTH
TRANSVERSAL BARS

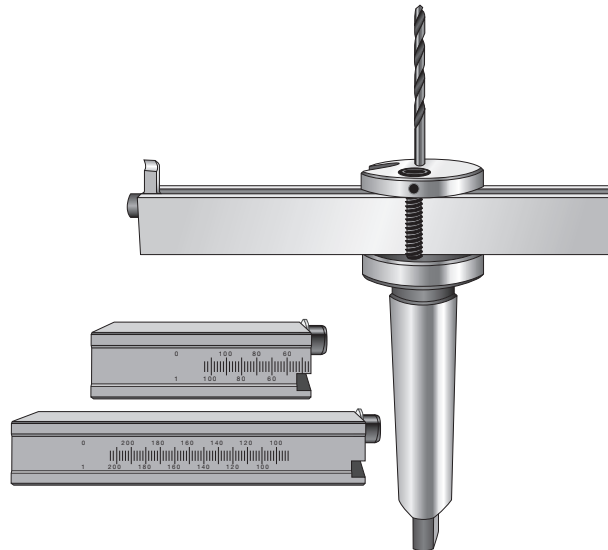

The Circular Hole Cutter is designed for cutting 1-3/16" to 11-13/16" holes in steel and non-ferrous metals. Cuts holes using the "drag-cut" principle. Very stable during machining. Faster than drilling, milling and boring. Ideal for fixed setups on product runs. Spoon shape blade allows a positive cut and is regrindable.

SIZE	CUTTING DEPTH	CUTTER SIZE	SHANK	ITEM NO.	PRICE
1-3/16 to 11-13/16 holes	1/2	5 mm	2 MT	CHC#2MT	136.50
1-3/16 to 11-13/16 holes	1/2	5 mm	3 MT	CHC#3MT	136.50